

TAKAHASHI Super Apochromat

TSA-120

INSTRUCTION MANUAL

TAKAHASHI

Thank you very much for your purchase of the Takahashi TSA-120 apochromatic refractor. Your first view will show a color-free, high contrast image with pin point stars. You are now ready to use your TSA both visually and for imaging.

In order to use your TSA-120 to the limit of its capabilities, please read this instruction manual carefully and familiarize yourself with all the features and functions of this instrument. The TSA-120 has been inspected by factory technicians before shipment. If the instrument should need service, please contact your local Takahashi distributor for authorized service.



WARNING

NEVER TRY TO OBSERVE THE SUN THROUGH THIS TELESCOPE WITHOUT THE PROFESSIONALLY DESIGNED FILTER FOR THE PURPOSE OF SOLAR OBSERVING. DIRECT VIEWING OF THE SUN WILL CAUSE INSTANT BLINDNESS. KEEP THIS TELESCOPE OUT OF THE REACH OF CHILDREN. COVER FINDERS WITH A SMALL SUN FILTER IF IT IS USED.



CAUTION

- The TSA-120 has been collimated by highly trained technicians. If you feel your instrument is out of collimation, please contact your local distributor for service.
- Keep the lens cap on the TSA when not in use. This will help prevent dust from collecting on the surface of the lens.
- Should cleaning be necessary, please contact your local distributor before proceeding for the correct procedure for cleaning the lens surface.
- Never remove the lens cell from the TSA. Doing so will void the 5-year warranty. If service is needed, please contact your local distributor.

Table of Contents

Warning & Caution	2
Contents	3
What is the TSA-120?	4
Specifications	5
Tube Assembly Layout	6
Attaching Finder & Tube Assembly	7 - 10
Finder Alignment	11-12
Observation	13-14
Accessories for Photo-Visual Applications .	15-21
Care & Maintenance	22-23
System Chart	24-27

What Is the TSA-120?

Takahashi has designed a new triplet apochromat. This design places the ED element in the middle position. The TSA design reduces color aberration (the halo in F and g lines) to 1/3rd that of a fluorite apochromat.

The TSA has been designed to imaging applications using a CCD, DSLR cameras when used with the TOA reducer and 35-Flattener. The 35-Flattener produces 10 micron stars across a 35mm photographic field, while the reducer produces a flat field with 10 micron stars in the middle.

The TSA-120 is the second in a series of compact, color-free light weight apochromatic refractors.

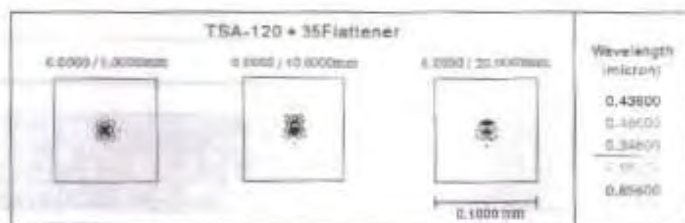
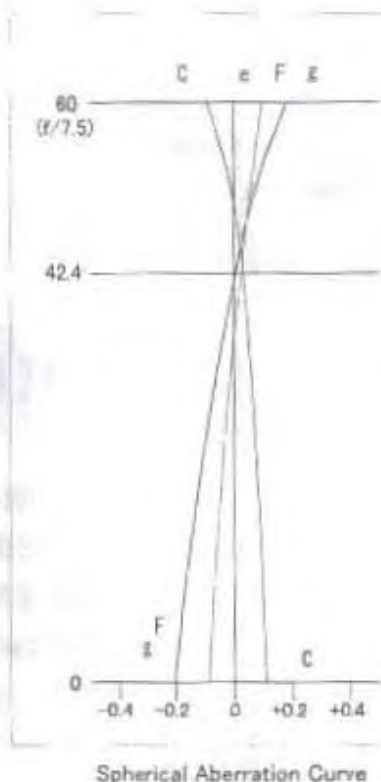

Spot Diagram by photographic angle when used with the 35-flattener

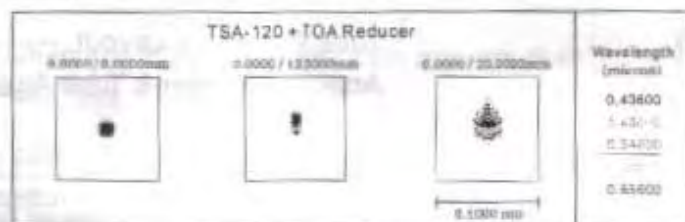

Spot Diagram by photographic angle when used with the reducer

SPECIFICATIONS

Effective Aperture	120mm
Focal Length	900mm
Focal Ratio	1: 7.5
Focal Length with reducer	670mm
Focal Ratio with reducer	1: 5.6
Resolving Power	0.97"
Limiting Magnitude	12.1
Light Gathering Power	293X
Image Circle with 35Flattener	ϕ 40mm
Photographic Field with 35Flattener ...	2.6°
Image Circle with Reducer	ϕ 50mm
Photographic Field with Reducer	4.2°
Diameter of Main Tube	125mm
Total Length of Main Tube	990mm
Total length with lens shade retracted	713mm[28"]
Weight of Tube Assembly	abt. 5.7kg[12.6lbs]
Finder Scope	7x50mm 6.3°

Tube Assembly Layout

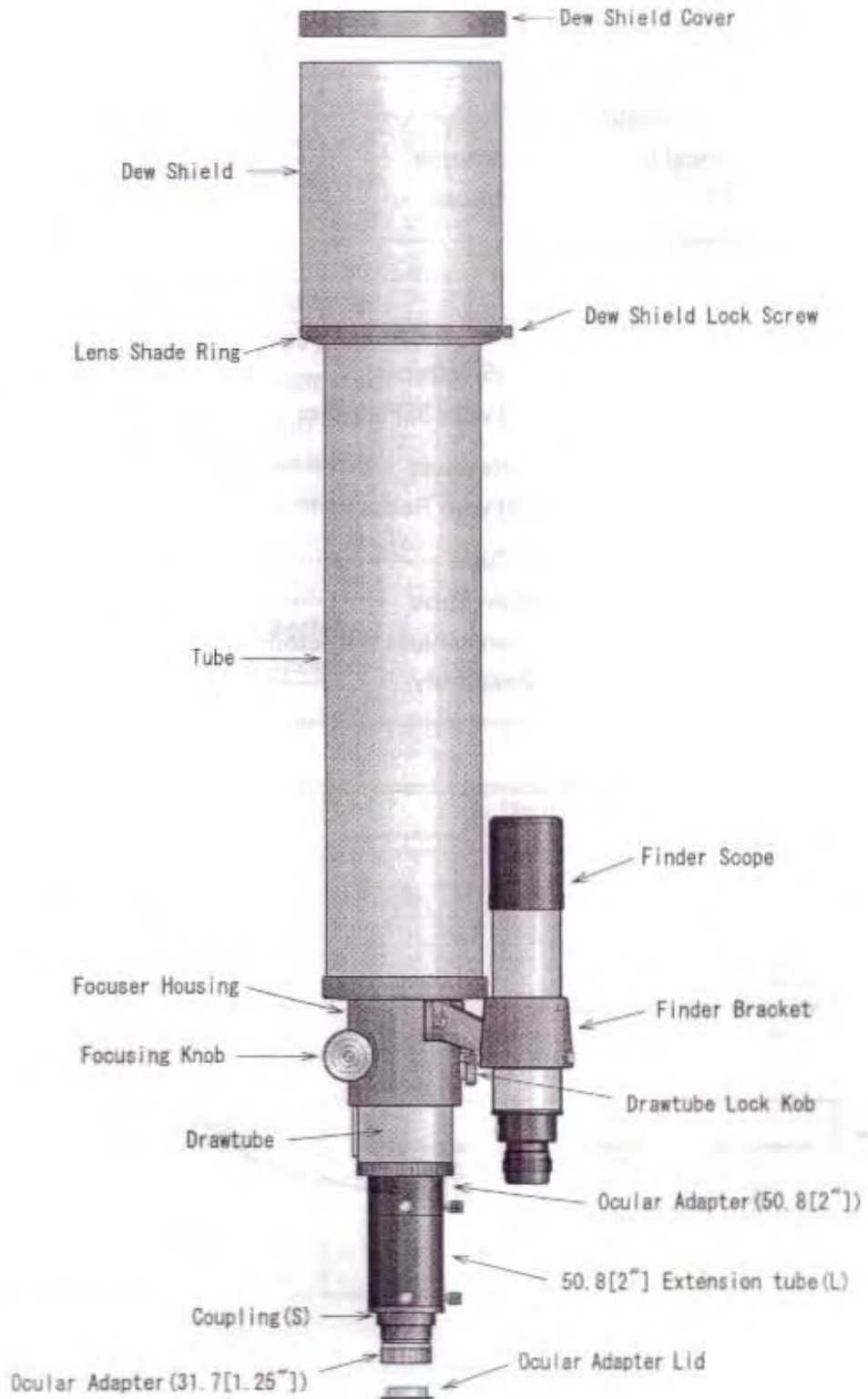

Fig.1

Attaching The Finder And Tube Assembly

If you have purchased the TSA-120 as a set or purchased the finder and bracket, the finder and bracket have been shipped unattached. Use the following instructions to attach and align the finder.

■ Attaching the Finder

Place the finder bracket over the two holes on the left side of the focuser and attach the bracket with the Allen screws supplied with the finder bracket. Make certain that the screws are tightened sufficiently to keep the finder bracket from moving thereby misaligning the finder.

Before inserting the finder into the finder bracket, using standard cellophane tape, place a double layer of this tape around the finder where the three set screws located in the front of the finder bracket will come into

contact with the finder. This will help prevent the finder tube from being scratched by the screws. Loosen the front and rear finder bracket screws. Loosen the front and rear finder bracket screw and carefully insert the finder into the bracket while holding the finder as parallel as possible to the tube assembly to allow the finder to be inserted and the screws to be tightened as evenly as possible. Doing this will allow the finder to be more easily aligned with the main optics.

If a finder illuminator will be used, remove the chromed cap screw located in front of eyepiece. Refer to Fig. 2 & 3.

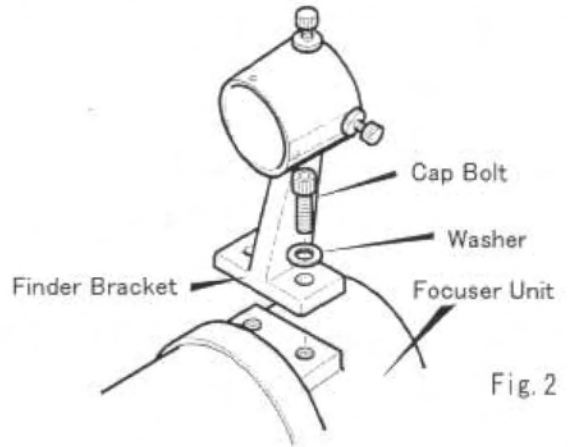

Fig. 2

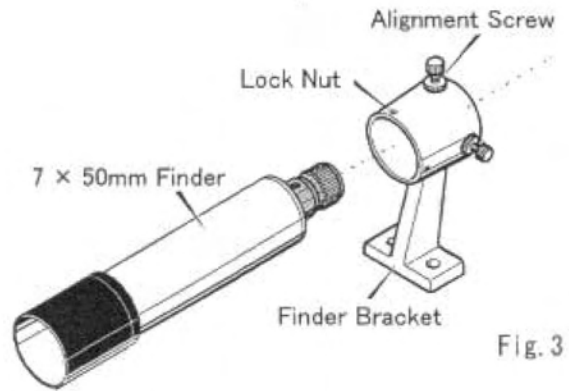

Fig. 3

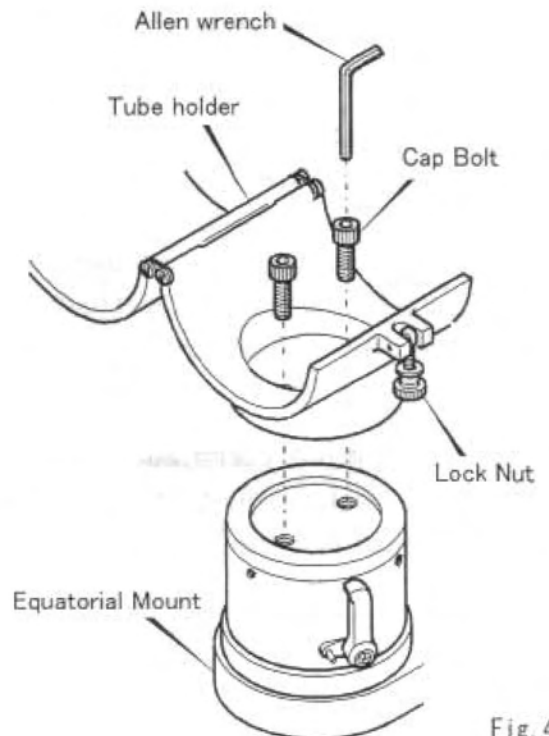

Fig. 4

■ Attaching the Tube Assembly to the Mount

Attach the tube holder to the mount using the 8mm Allen screws supplied with the tube holder as shown in Fig. 4. The tube assembly can then be placed into the tube holder and secured with the lock nut after the clam shell has been closed over the tube assembly. This tube holder can be used with all Takahashi mounts. If astro imaging is one of the uses, then the heavier duty the mount is the better it will be to image. In the case of the TSA-120, this would be the Takahashi EM-200 mount.

The correct way to attach the tube holder to the mount is to use the Allen screws provided with the tube holder. After placing the tube assembly into the tube holder, the next step is balancing. Refer to Fig. 5.

Now that the instrument has been attached to the mount, it will be necessary to balance the load in the R.A. and the Dec.

The first step is to clamp the R.A. and unclamp the Dec. Hold the tube of the telescope in the event it is out of balance. Then, loosen the tube clamp slightly so that the tube can be moved in either direction. Move the tube in either direction until it balances. When the tube is balanced, tighten the clamp.

Next, loosen the R.A. clamp, and tighten the Dec. clamp. Unclamp the counter-weight(s) and slide them in either direction until the package is balanced.

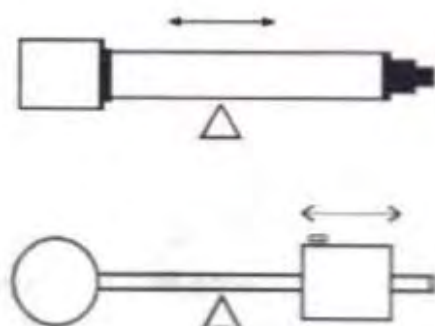

Fig. 5

● How To Retract The Lens Shade

The Lens Shade of the TSA-120 is retractable. When the TSA-120 is to be transported, retract the lens shade until it rests on the ring installed in the tube assembly for that purpose. The shade can be extended when the TSA-120 is used.

1. Remove the cap of the dew shield.
2. Loosen the two lock screws.
3. Extend the dew shield.
4. Turn the locking screws until they make contact.



Fig. 6

[Caution]

Remove the lens shade cap before moving the Lens shade. The fit is tight enough to blow the lens shade cap off of the lens shade and it allows the lens shade to move easier.

■ Compression Ring

Remove the ocular adapter cover after the locking ring has been loosened by turning it counter clockwise. Then, insert the desired ocular or 31.7(1 1/4") diagonal into the adapter and tighten the ocular ring by turning it clockwise.

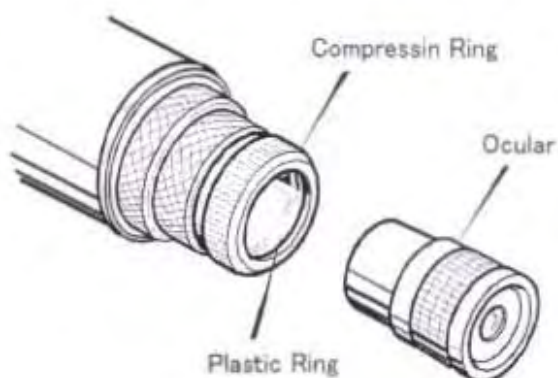

Fig. 7

■ Connection the System Parts

The adapters and the rings are provided on the visual back to connect various system parts. Carefully study the system chart in this book before connecting any system parts. Connection of the incorrect parts may prevent the telescope from coming to a sharp focus or any focus at all. Refer to the Fig. 8 for a standard connection.

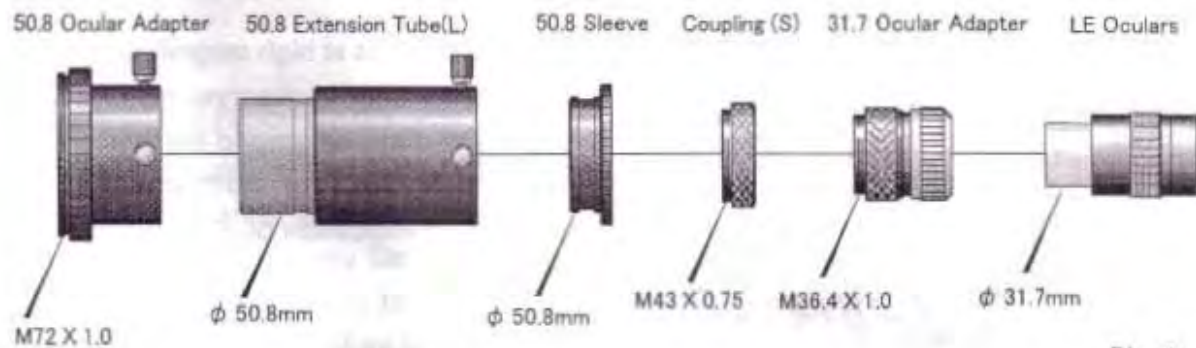

Fig. 8

■ Focusing

After inserting the ocular into the telescope, it is necessary to achieve the best possible focus. Remember the atmosphere will limit the highest magnification that can be used on any given night. Using the lowest power ocular; focus the image and then increase the magnification by using shorter and shorter focal length oculars until the desired magnification is reached. This procedure allows the centering of an object at high magnification. Please familiarize yourself with the following.

● Focusing System

The TSA-120 uses a rack-and-pinion focuser. This focuser enables the observer to focus rapidly. Turning the focuser clockwise will move the drawtube out, while turning the counter-clockwise will move the drawtube in. Refer to Fig. 9. The optional Micro Edge Focuser [MEF-3] adds 7 to 1 fine focus for fine focusing at high magnification or for imaging.

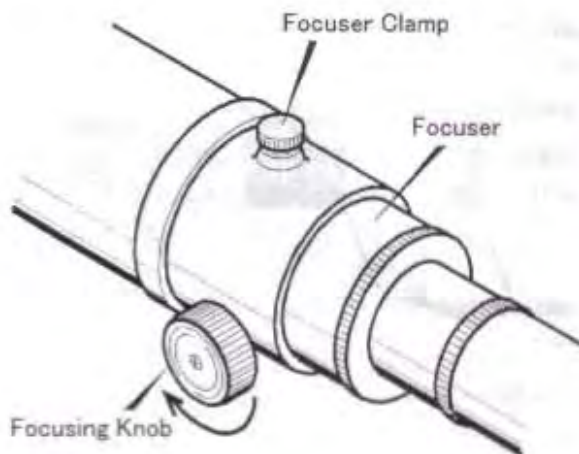

Fig. 9

Remove the lens shade cover and the aluminum plug from the 31.7mm compression ring adapter. Insert the diagonal into the compression ring adapter. Carefully tighten the compression ring until it begins to make contact with the barrel of diagonal. It is not necessary to overtighten the ring to hold the diagonal.

Then insert the ocular into the compression ring of the diagonal, repeating previous process. Be careful not to overtighten the compression ring.

Begin the focusing process by choosing a bright star in a convenient position. When you think that you have achieved the best focus, move the focuser inside and outside of what you think is the best focus. This will confirm the critical procedure.

Begin with a low power ocular and then proceed higher and higher until the desired magnification has been achieved.

When best focus at high magnifications has been achieved, the observer may notice a bright and dim ring around the star. This is not a defect but rather a diffraction pattern which is an indication of diffraction limited optics.

Finder Alignment

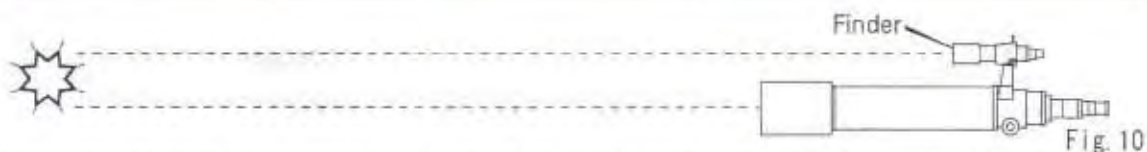

Before the finder is placed in the finder holder, use plastic clear tape and tape the finder with two layers to prevent the tube from being scratched by the front finder set screws.

A finder is a useful tool. It permits the precise centering of an object in the field of view. The 6.3° field of view allows the easy centering of an object to be viewed or photographed.

The Takahashi finder uses an interrupted crosshair which is designed to allow the easy centering of an object to be photographed or observed. The wide field of the finder makes the finding of an object easier, therefore, it is important that the finder and the telescope be in alignment. The following procedure can be used to align the finder.

◆ Alignment Procedure

1. Place a low power eyepiece in the telescope and center a bright star in a convenient part of the sky. Do not forget to engage the motor drive to keep the star centered. If this procedure is done in daylight, use an object that is at least one mile away. Loosen the lock nuts on the finder bracket and slightly move the star to the center of the field using the adjusting alignment screws.

2. Then use a higher magnification eyepiece and repeat the procedure by centering the object in the field of view of the telescope and then the finder. Continue this process until the highest possible magnification has been used.

◆ Adjusting Screw Procedure

1. Turn all the lock nuts until they reach the head of the alignment screws.

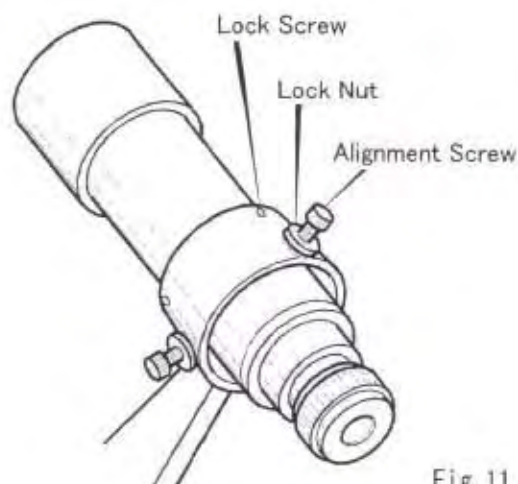

Fig. 11

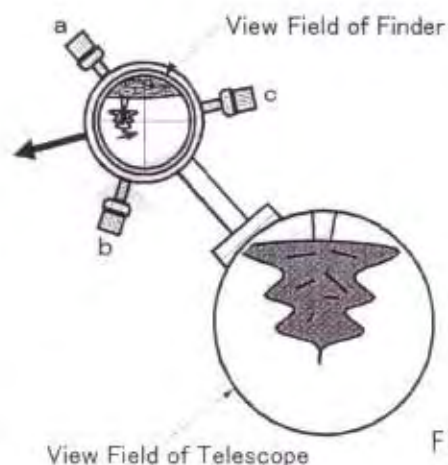

Fig. 12

2. In order to move the crosshair in the direction of the arrow, first loosen screw (a) and tighten (push) the finder with screw (c). This procedure will move the crosshair in the desired direction. The top of the finder will move in the opposite direction and the object will move in the direction of the smaller arrow. Refer to Fig. 12.

3. In a similar fashion the direction of the movement of the finder is made by adjusting the three screws.

Learn the relationship between the movement of the three adjusting screws. If the finder cannot be moved in the desired direction, loosen the locking nuts.

◆ Reticle Illuminator [Optional]

The 7x50mm finder has provision for an optional reticle illuminator.

If an illuminator will be installed, remove the cap screw at the end of the finder and install the reticle illuminator. The illuminator makes the centering of dim objects easier.

In order to turn the illuminator on, turn the

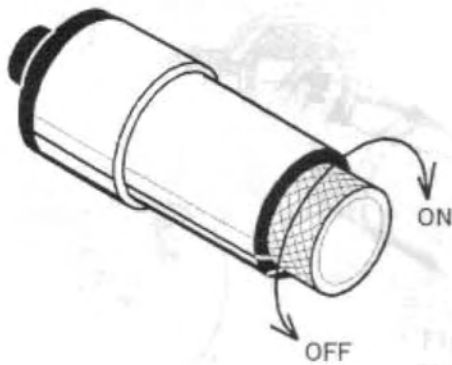

Fig. 13

knob clockwise. The knob will click when the illuminator turns on. As the knob is turned, the reticle will brighten. Adjust the knob to the desired brightness. Turn the knob counter-clockwise past the click to turn the illuminator off. Refer to Fig. 13.

◆ Replacing The Battery

Before changing the batteries in the illuminator, please be certain to turn it off. Unscrew the battery holder as shown in Fig. 14. Remove the old batteries and insert new one after they have been wiped with a clean dry cloth. Check the polarity of the batteries before inserting them into the holder. Use two silver [V76-PK] or equivalent batteries.

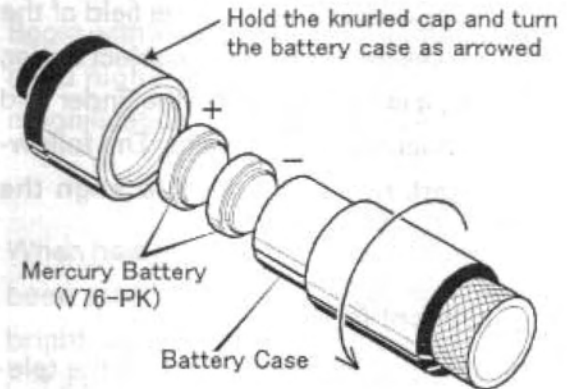

Fig. 14

Observation

■ Visual Applications

◆ Determining Magnification

The magnification of any ocular used with the telescope can be calculated by using the following formula.

$$\frac{\text{(focal length of a telescope)}}{\text{(focal length of an ocular)}}$$

Therefore, shorter focal length eyepieces will produce higher magnification. During a night of good seeing, the TSA-120 can be used at up to 100x per inch of aperture. These rare nights of exceptional seeing will reveal fine planetary filaments and small craterlets on the moon. At the lower end, about 10X per inch or so will produce breathtaking wide field view of nebulae and comets.

◆ Compression Ring Star Diagonal

The 31.7 (1 1/4") diagonal prism is inserted into the compression ring adapter at the end of the focuser and tightened until it holds the diagonal in place. Then the ocular can be inserted into the compression ring adapter of the diagonal and tightening the compression to hold the ocular.

◆ Lunar observation

The moon is an excellent object for beginners and advanced amateur astronomers as well. The entire Moon can be viewed at about 50X, but on clear night near full Moon, it is best to use a 58 green, 3N5 or variable polarizing filter to view the entire disk.

Using higher magnification during any Moon phase will allow the observer to see fine detail such as ray structures, craterless and small rilles. For this type of observation the filter is normally removed because as the magnification goes up, the image brightness decreases. The ultra high contrast images produced by the TSA-120 will amaze the observer.

In order for the observer to enjoy a variation of magnified observation without troublesome attaching and detaching oculars, 5-turret ocular holder is optionally available. Refer to the system chart.

◆ Planetary observation

The TSA-120 is particularly suited for planetary observation. The high contrast, very sharp images will reveal a wealth of planetary detail.

In order to see this fine detail the night should be very steady. If the stars at the zenith twinkle a good bit, the the planets will look sharp at low magnification. When the star at the zenith is steady then high magni-

fication can be used to reveal a wealth of detail. Magnifications of 100x per inch can be used.

These nights of steady seeing will also produce fine images using a digital SLR or a 35mm camera using Fuji Velvia slide film. Effective focal ratios in excess of f/100 can be used.

◆ Observation of deep sky objects

In general, observing deep sky objects requires a low power, wide field ocular which produces the maximum brightness. On the other hand, observing globular clusters and small nebulae requires high magnification. This is particularly true in cities with high sky brightness. High magnification will help reduce the sky background and hence improve the contrast necessary to view the object(s).

■ Astro Imaging

Focusing is the most critical element of making great astro images. Once critical focus has been achieved, then outstanding images can be made. It is a good practice to recheck critical focus before image is made.

◆ Eyepiece Projection Imaging

When you want to make lunar or planetary images the TCA-4 is designed to make eyepiece projection imaging easier and versatile. The TCA-4 will accept any Takahashi LE 31.7 (1 1/4") ocular and variable feature sliding tube gives the imager latitude in determining the size of the final image.

◆ Seeing

Highly magnified lunar or planetary images can only be made when the seeing is very steady [excellent]. 10 being the best seeing with a star at the zenith not twinkling at all. If it is twinkling rapidly, the seeing is between 1 to 4. If the twinkling is moderate this is 5-6. If the star twinkles slowly to no twinkling, we have the 7 to 10 night. The less twinkle the better.

Cautions

When making high magnification images of the Moon and planets, pay careful attention to balance. Rebalance the telescope when the object is placed in the center of the camera.

If the telescope is moved to another object, then rebalance it in the position in which the photos will be taken. Do not use the camera shutter; use the "hat trick" a black card placed over the lens shade before the shutter is set on bulb. After the vibration has stopped, remove the black card for the duration of the photo, which will normally be in seconds.

Accessories for Photo/Visual Application

■ 31.7(1 1/4") Compression Ring Diagonal and 50.8(2") Mirror Diagonal

Both of these diagonals take up different amounts of back focus. This is noted on the diagram. The 31.7(1 1/4") prism diagonal will require the focuser to be racked out further.

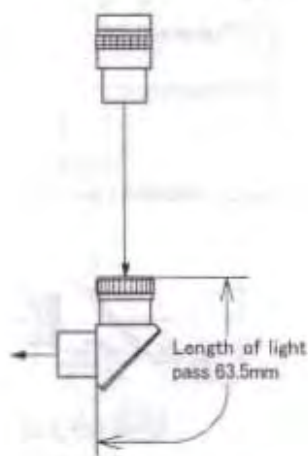

31.7(1 1/4") Prism Diagonal

Fig. 15

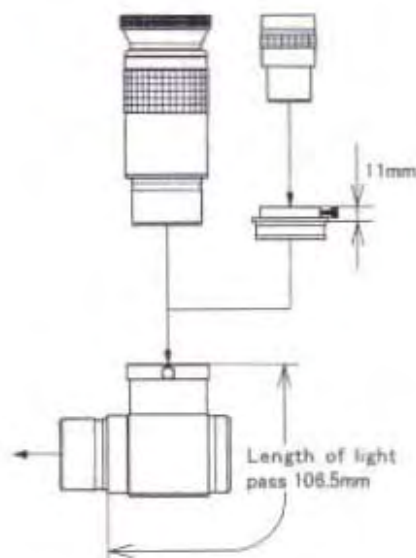

50.8(2") Mirror Diagonal

Fig. 16

■ 2X Barlow Lens

This Barlow lens was originally designed for the FS Series and it can be used for the TSA for visual use. This short Barlow can be used with the 31.7(1 1/4") diagonal or 50.8(2") mirror diagonal.

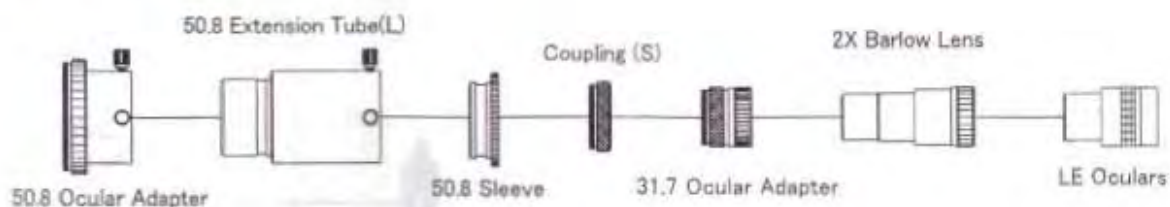

Fig. 17

■ 5-Turret Ocular Holder

5-turret Ocular Holder is a unique ocular holder that can attach five different 31.7 (1 1/4") oculars to view an object with five different magnifications quickly by turning the holder. Refer to Fig. 18,19.

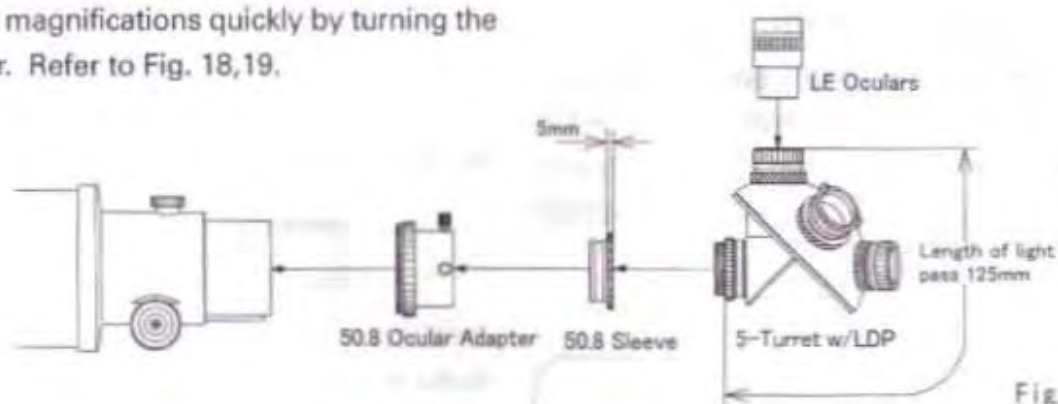

Fig. 18

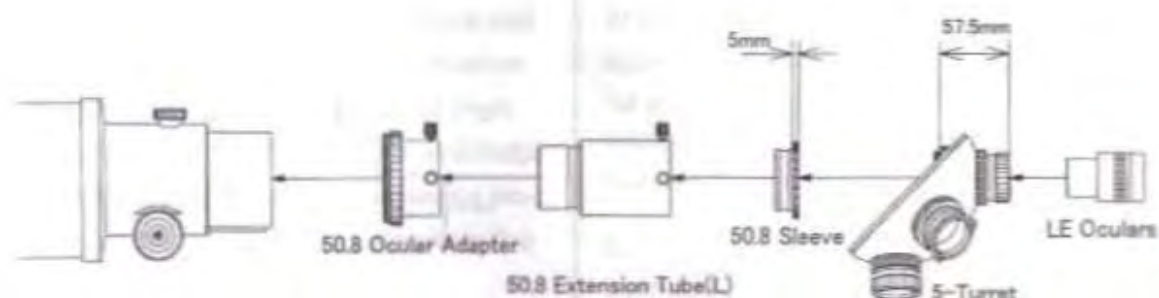

Fig. 19

■ 35 Flattener

This flattener is specially designed to produce a flat field for use with a 35mm SLR, DSLR, and CCD camera or visually. It is necessary due to the generous back focus to use the CA-35 (50.8)(2").

Focal Length 880mm

Focal Ratio F: 7.3

Image Circle ϕ 40mm [60% illuminated]

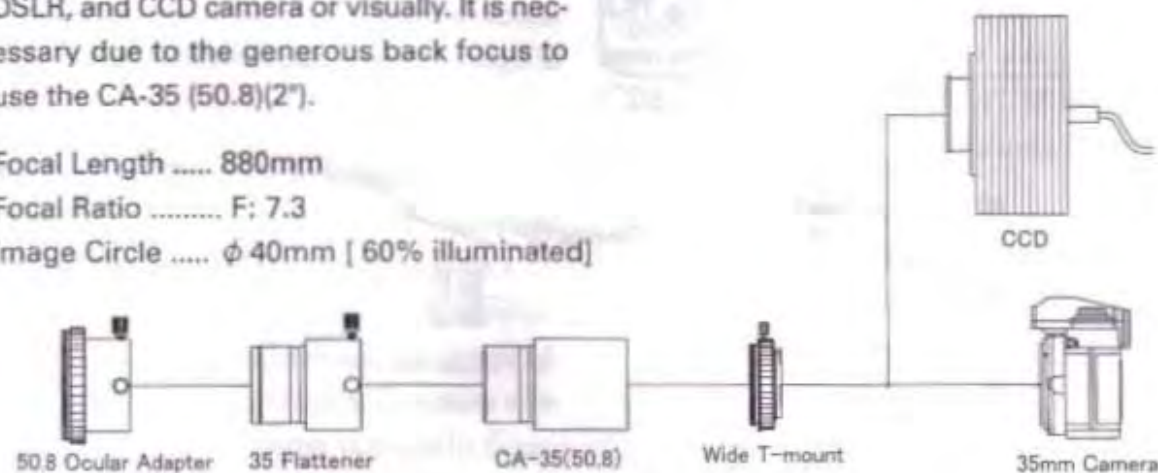

Fig. 20

■ Reducer

This newly developed reducer uses 2 multi-coated elements to produce a flat field with a faster focal ratio than the f/7.5 to f/5.6. The stars still remain under 20 microns, which make it useful for CCD cameras with smaller chips.

Focal Length 670mm

Focal Ratio F: 5.6

Image Circle ϕ 50mm [60% illuminated]

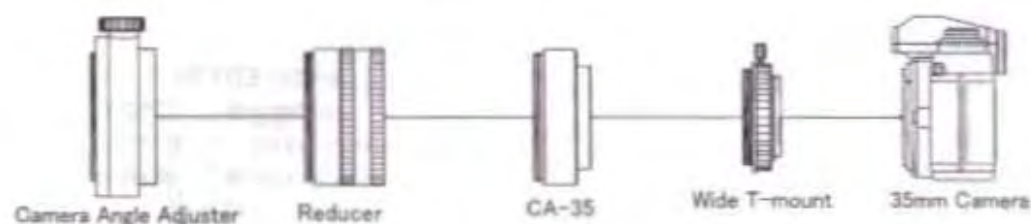

Fig. 21

■ Camera Angle Adjuster (CAA)

The Camera Angle Adjuster allows a camera or ocular and diagonal to be rotated 360° without loss of focus.

It allows the ocular to be placed in a convenient position or it allows the camera to be rotated to properly frame an image without loss of focus.

This model will fit the Takahashi refractors with the 2.7" focuser.

■ Extender-ED 1.5X

The Extender-ED 1.5X is newly designed a two element extender, with an ED glass being used for one of the element, that increases the focal length of the TSA-120 to 1350mm. The Extender-ED 1.5X uses a 50.8mm(2") barrel that allows cameras and adapters to be easily taken off or attached to the Extender-ED 1.5X. The longer focal length will produce stunning images of the Moon and planets. A 35mm camera can be attached to the Extender-ED 1.5X with a 50.8 extension tube and wide T-mount camera adapter. When it is used with the 35-Flattener, it produces a flat 44mm dia. circle for visual, digital SRL camera CCD applications.

- Extender ED1.5x
 - Focal length 1350mm
 - Focal ratio f/11.3
 - Image circle ϕ 44mm

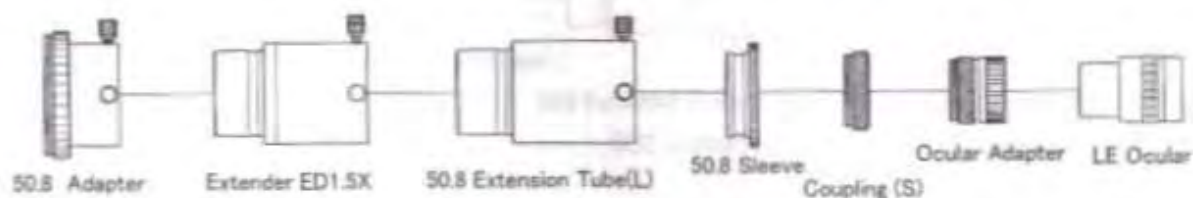

Fig. 22

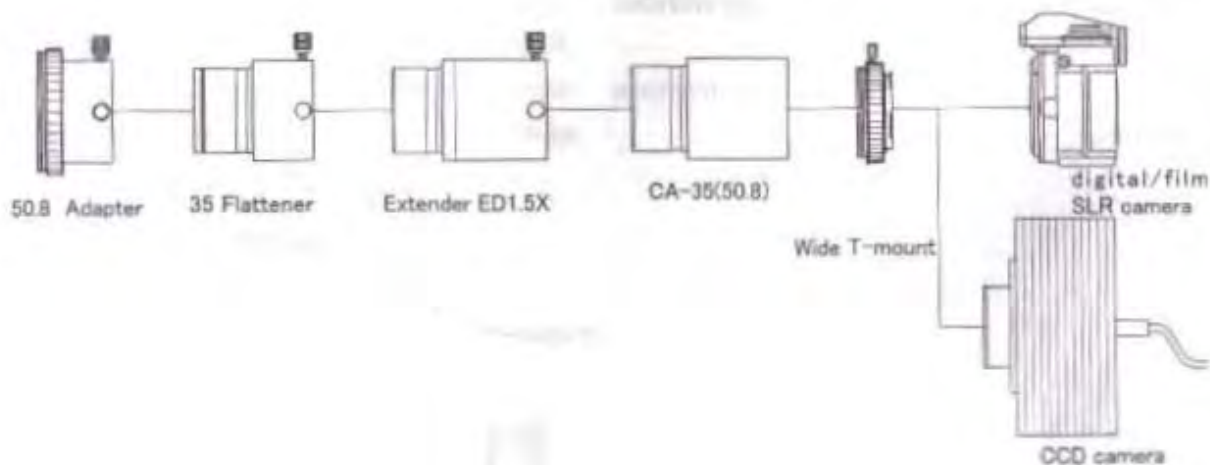

Fig. 23

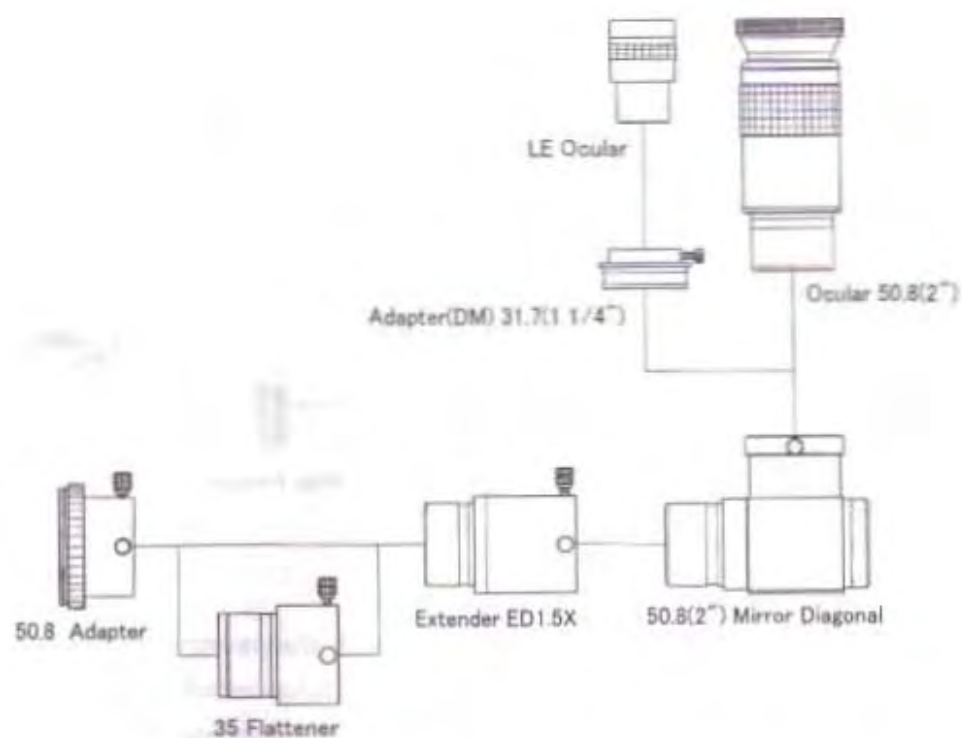

Fig. 24

■ CA-35

There are two different 35mm camera adapter available that will allow an SLR/ DSLR and CCD camera to be attached to the TSA-102.

a. CA-35(50.8)[2"] for imaging.

Refer to Fig. 23

b. CA-35(TSA-102) for imaging with the reducer.

Refer to Fig. 24

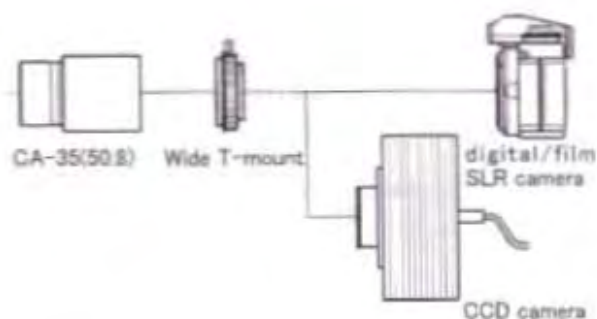

Fig. 25

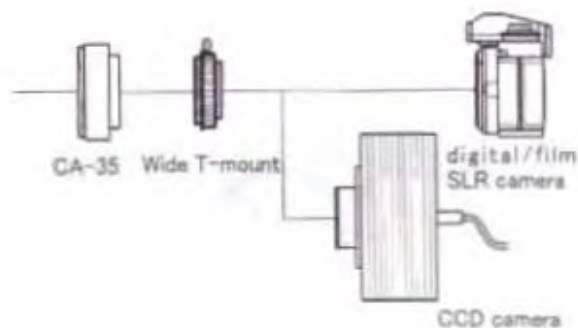

Fig. 26

■ T-Mount & Wide Mount T-Adapters

The T-mount adapter is used to attach the TCA-4 eyepiece projection adapter for high magnification imaging with a digital SLR or CCD cameras of the Moon and planets. Refer to Fig. 25.

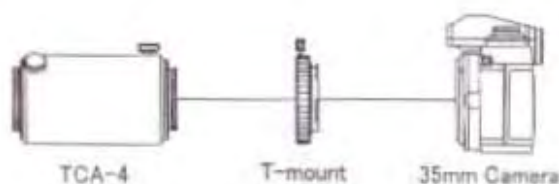

Fig. 27

The Wide T-Mount can be used for prime focus, reducer, 35-flattener photography. Refer to Fig. 26.

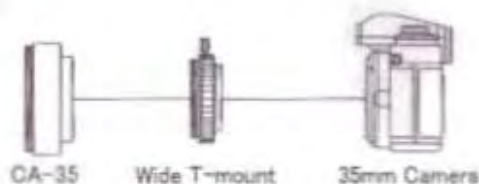

Fig. 28

■ TCA-4

This variable eyepiece projection device attaches easily to the TSA for high quality high magnification photos of the surface of the Moon and planets. It can be used with a film or CCD camera. Refer to Fig. 27.

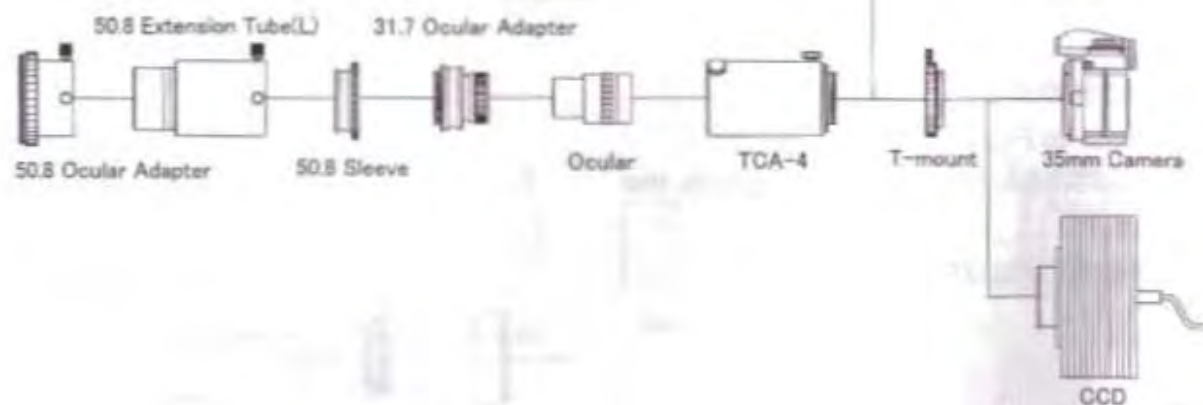

Fig. 29

■ MEF-3

The Micro Edge Focuser is an optionally available 7 to 1 fine focus attachment that permits 7 to 1 fine focus for critical focusing for imaging or high magnification. (Standard on U.S. Version.)

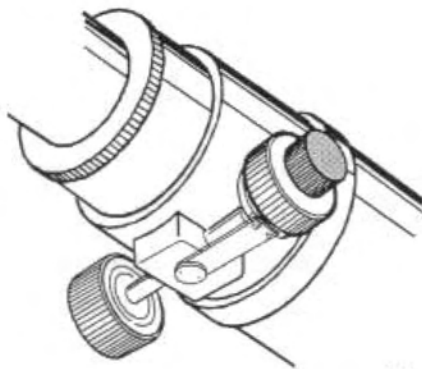

Fig. 30

■ FQR-1

FQR-1 is very convenient device to attach and detach the finder quickly. Once it is set on the focuser housing, you can attach and detach the finder quickly by thumb turn screw. The finder alignment remains almost the same in doing so. This is optionally available.

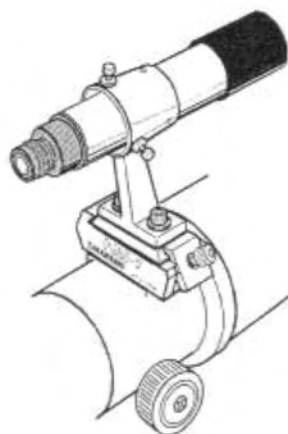

Fig. 31

■ Sun Observation

The high quality optics of the TSA-120 will provide outstanding images of the Sun. It is best to use high quality glass filters or H-alpha filter.

Never observe the sun directly. This will cause instant blindness. Cover your finder with two layers of aluminized Mylar, or an opaque cover finder to allow the observer to center the sun.



Care & Maintenance

- ◆ Before Attempting To Clean Your Optics, Contact Your Local Distributor For Precise Instruction Or Advice On How To Proceed.
- ◆ If the front lens of the objective has dust or dirt particles on it, use a large hand powered blower to remove the particles. Under no circumstances should dust be removed by any other means, rubbing the surface will cause scratches. If the lens must be cleaned, be certain that all dust and dirt particles have been removed by using a blower. Then using cotton swabs slightly moistened with cleaner dab the surface, changing cotton swabs often until the objective is cleaned. If any questions arise during this process, immediately contact you local distributor for help. Under no circumstances should the surface ever be rubbed.
- ◆ **REMEMBER, DO NOT USE ANY FORM OF CANNED AIR TO REMOVE THE PARTICLES.**
This product is very cold and could harm the front lens of the objective. Be certain that the dew cap is removed before attempting to clean the objective. Use the following procedure, if the front and rear surfaces of the objective must be cleaned.

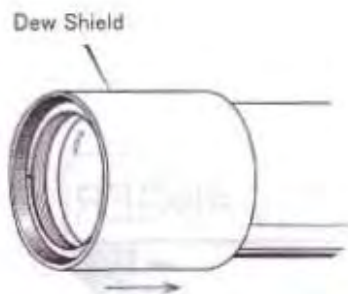

Fig. 32

1. Remove the dew shield from the cell by turning it counter-clockwise. In case of the dew shield is retractable, loosen the lock screws and remove it.
2. Remove the screws that attach the objective to the cell. These are the shorter screws with the larger heads. Always keep one hand on the objective as these screws are removed to keep it from falling. As you remove the objective cell, make two marks on the cell and base so that it will be placed back in its original position after cleaning. In the diagram the screws removed are called "pulling screws".
3. After cleaning, attach the objective again to the base, aligning the marks made on both when the objective cell was removed. If this is not done, the telescope will not be properly collimated. If you feel that you do not wish to do this procedure, contact your distributor. They can do this procedure and return the instrument to you.

Do not try to disassemble the lens cell for the lens cleaning. It will be impossible to collimate the objective without the special collimator.

If the telescope is used in condition of high humidity, be certain that it is taken indoors and dried out before it is stored. If the dew has not been dried and the instrument is stored, there will be a harmful residue left on the surfaces of the telescope. Leave the lens cap off until the objective lens is totally dried.

CONTACT YOUR LOCAL DISTRIBUTOR FOR PRECISE INSTRUCTIONS FOR CLEANING OR SEND IT TO THEM FOR CLEANING.

System Chart

■ Photo/ Visual System Chart

- 6. CAA [TKA30200]
- 13. 50.8 Sleeve [TKP00113]
- 14. Coupling (S)[TKA00103]

- 18S. Reducer [TKA31580S]
- 32. T-mount
- 33. Wide T-mount
- 34. Digital SLR
- 36. TCA-4 [TKA00210]
- 46. 31.7 Ocular adapter [TKP00101]
- 47. Ocular (31.7)
- 48. Ocular (50.8)
- 49. 31.7 Diagonal prism [TKP00541]
- 60. Extender ED1.5x [TKA00595]
- 70. 50.8 Ocular adapter [TKP27110]
- 71L. Extension tube (L)[TKP31112]
- 74. Diagonal mirror [TKA00543]
- 75. Adapter (DM) for #74 [TKA00111]
- 80S. 35 flattener [TKA31582]
- 86. CCD camera

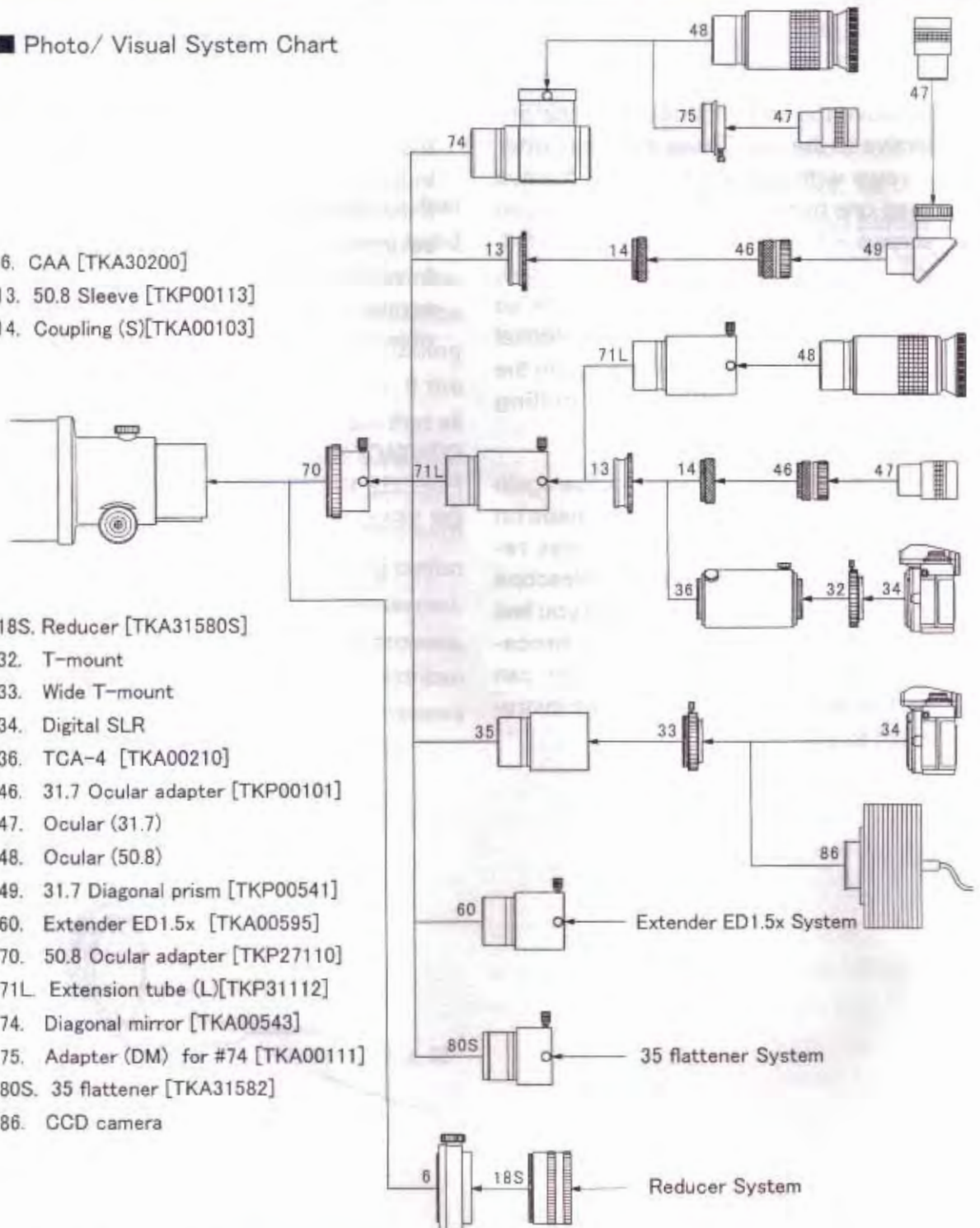

* No.13,14,46,70, and 71L are standard accessories for the visual back

* Some 35mm SLR/DSLR camera cannot be attached.

* Adapter(DM)(No.75) is provided with Diagonal Mirror(No.74).

■ 35 flattener System Chart

- 13. 50.8 Sleeve [TKP00113]
- 14. Coupling (S)[TKA00103]
- 46. 31.7 Ocular adapter [TKP00101]
- 70. 50.8 Ocular adapter [TKP27110]
- 71L Extension tube (L)[TKP31112]

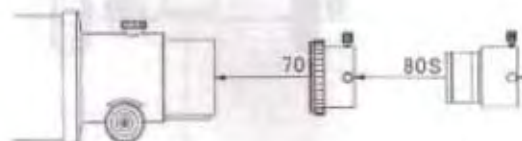

● Optional parts

- 32. T-mount
- 33. Wide T-mount
- 34. Digital SLR
- 35. CA-35(50.8) [KA31201]
- 36. TCA-4 [TKA00210]
- 47. Ocular (31.7)
- 48. Ocular (50.8)
- 60. Extender ED1.5x [TKA00595]
- 74. Diagonal mirror [TKA00543]
- 75. Adapter (DM)(31.7)[TKA00111]
- 80S. 35 flattener [TKA31582]
- 86. CCD camera

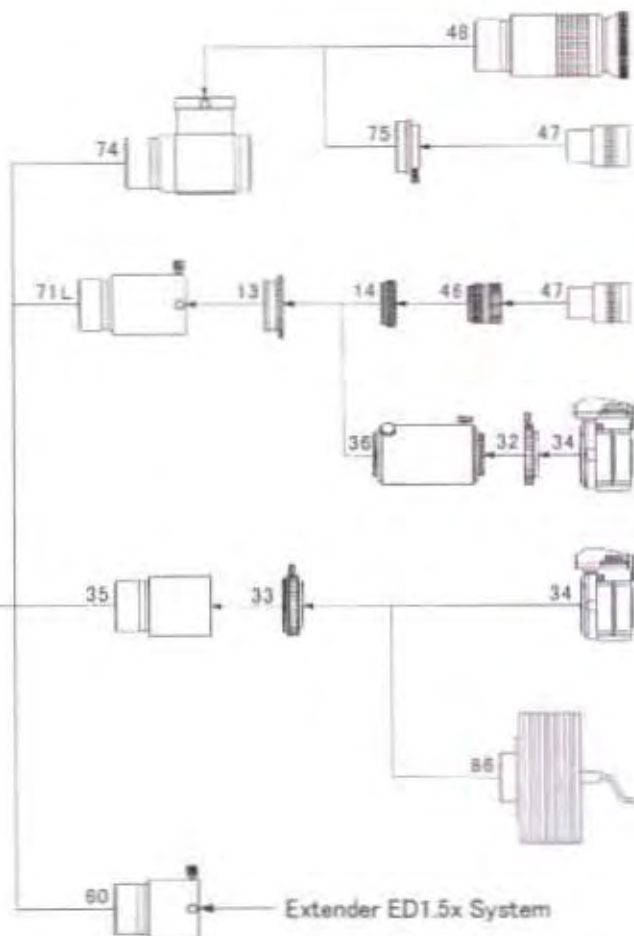

- * Some 35mm SLR/DSLR camera cannot be attached.
- * Adapter(DM)(No.75) is provided with Diagonal Mirror(No.74).

■ Reducer System Chart

- 13. 50.8 Sleeve [TKP00113]
- 14. Coupling (S)[TKA00103]
- 46. 31.7 Ocular adapter [TKP00101]
- 70. 50.8 Ocular adapter [TKP27110]

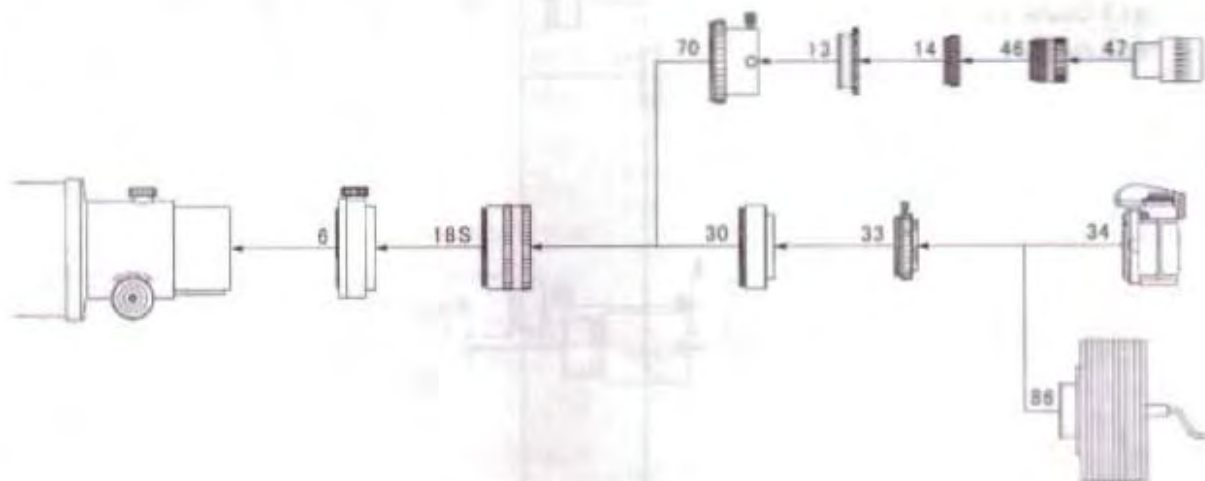

● Optional parts

- 6. CAA [TKA30200]
- 18S. Reducer [TKA31580S]
- 30. CA-35(TSA-102) [KA23201]
- 33. Wide T-mount
- 34. Digital SLR
- 47. Ocular (31.7)
- 86. CCD camera

* Some 35mm SLR/DSLR camera cannot be attached.

■ Extender ED1.5x System Chart

- 13. 50.8 Sleeve [TKP00113]
- 14. Coupling (S)[TKA00103]
- 46. 31.7 Ocular adapter [TKP00101]
- 70. 50.8 Ocular adapter [TKP27110]
- 71L. Extension tube (L)[TKP31112]

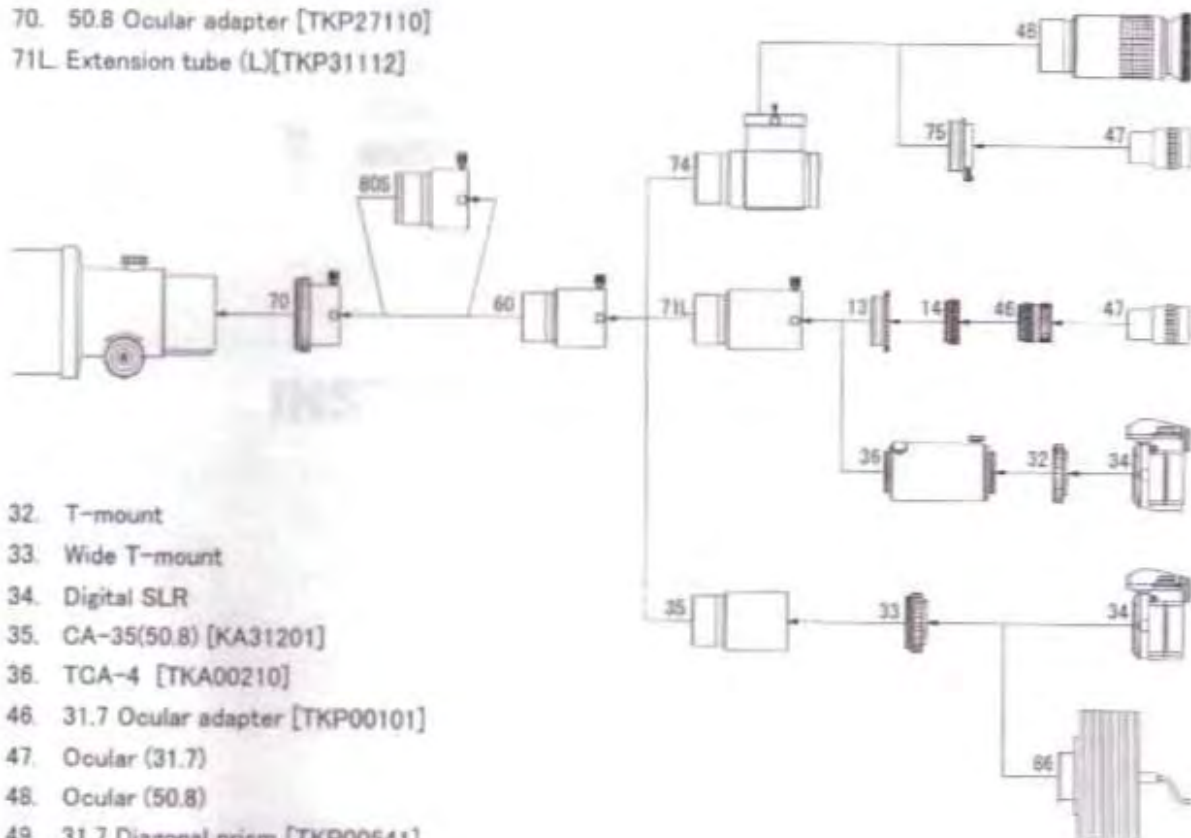

- 32. T-mount
- 33. Wide T-mount
- 34. Digital SLR
- 35. CA-35(50.8) [KA31201]
- 36. TGA-4 [TKA00210]
- 46. 31.7 Ocular adapter [TKP00101]
- 47. Ocular (31.7)
- 48. Ocular (50.8)
- 49. 31.7 Diagonal prism [TKP00541]
- 60. Extender ED1.5x [TKA00595]
- 74. Diagonal mirror [TKA00543]
- 75. Adapter (DM)(31.7)[TKA00111]
- 80S. 35 flattener [TKA31582]
- 86. CCD camera

- Some 35mm SLR/DSLR camera cannot be attached.
- Adapter(DM)(No.75) is provided with Diagonal Mirror(No.74).
- When the Extender-ED1.5x is used, use the 35-Flattener together in order to mark the field flat. Without the 35-Flattener, the photographic field will not be flat due to the curvature of the field, resulting photographic images worse toward the edges of the field.