

**Dall-Kirkham**

---

***Mewlon-180C***

**Instruction Manual**

**TAKAHASHI**

Thank you very much for your purchase of the Takahashi Mewlon-180C telescope. This model is the lightest and most compact one in all Mewlon series with 50.8(2") system provided. The mirrors are coated with a HR multi-layer coating.

In order to use the telescope to its highest possible capabilities, please read this instruction manual very carefully and familiarize yourself with all of the functions that your telescope offers.

All Takahashi telescopes have been strictly inspected before shipment. If there is any trouble with your telescope when unpacked, please contact your authorized dealers for proper attention.

# Precautions for Safe Operation



## WARNING

If a telescope is pointed at the sun, its light and heat concentrated at the focal point will be intense and dangerous. **NEVER LOOK THE SUN DIRECTLY. VIEWING THE SUN WITHOUT PROPER FILTERS MAY RESULT IN BLINDNESS.**



## CAUTION

- ◆ When attaching the tube assembly onto the equatorial mount, be careful not to pinch your fingers or to drop the tube assembly.
- ◆ Always lay the tube assembly on a completely flat surface that totally supports it to protect it from damage.
- ◆ Keep the tube assembly out of the sun to prevent the light of the sun going into the tube, the reflected sunshine can cause great heat at the focal point and become so intense that it could start a fire.
- ◆ When focusing, be careful not to pinch your fingers.
- ◆ Keep children away from small parts that could be swallowed and keep them away from plastic bag that covers the tube assembly.
- ◆ Keep away all packing materials from an open flame. These materials are flammable.

# Contents

Precautions for Safe Operation .....	3
Contents .....	4
Specifications .....	5
Tube Assembly Layout .....	6
Features .....	7
Setup Procedures .....	8
Focusing .....	11
Finder Adjustment .....	12
Observation .....	14
Accessories .....	15
Collimation .....	18
Care & Maintenance .....	20
System Charts .....	21

# Specifications

Optical System	Dall Kirkham
Effective Aperture	180mm HR Multi-Coated
Effective Focal Length	2160mm
Effective Focal Ratio	1:12.0
Secondary Mirror	54mm HR Multi-Coated
Resolving Power	0.64"
Limiting Magnitude	13.0
Light Gathering Power	661x

When used with Mewlon Flattener/Reducer

Effective Focal Length	1760
Effective Focal Ratio	1:9.8

Tube Diameter	210mm
Total Length of Tube	625mm
Total Weight of Tube	6.2kg (13.6lbs)
Finder Scope	6x30 built-in
Accessories	Dove-tail Adapter (F), Warranty Card, Instruction Manual, Tools (Hex Wrench 1.5mm & 2.5mm)

**(Note)** HR = High Reflectance

# Tube Assembly Layout

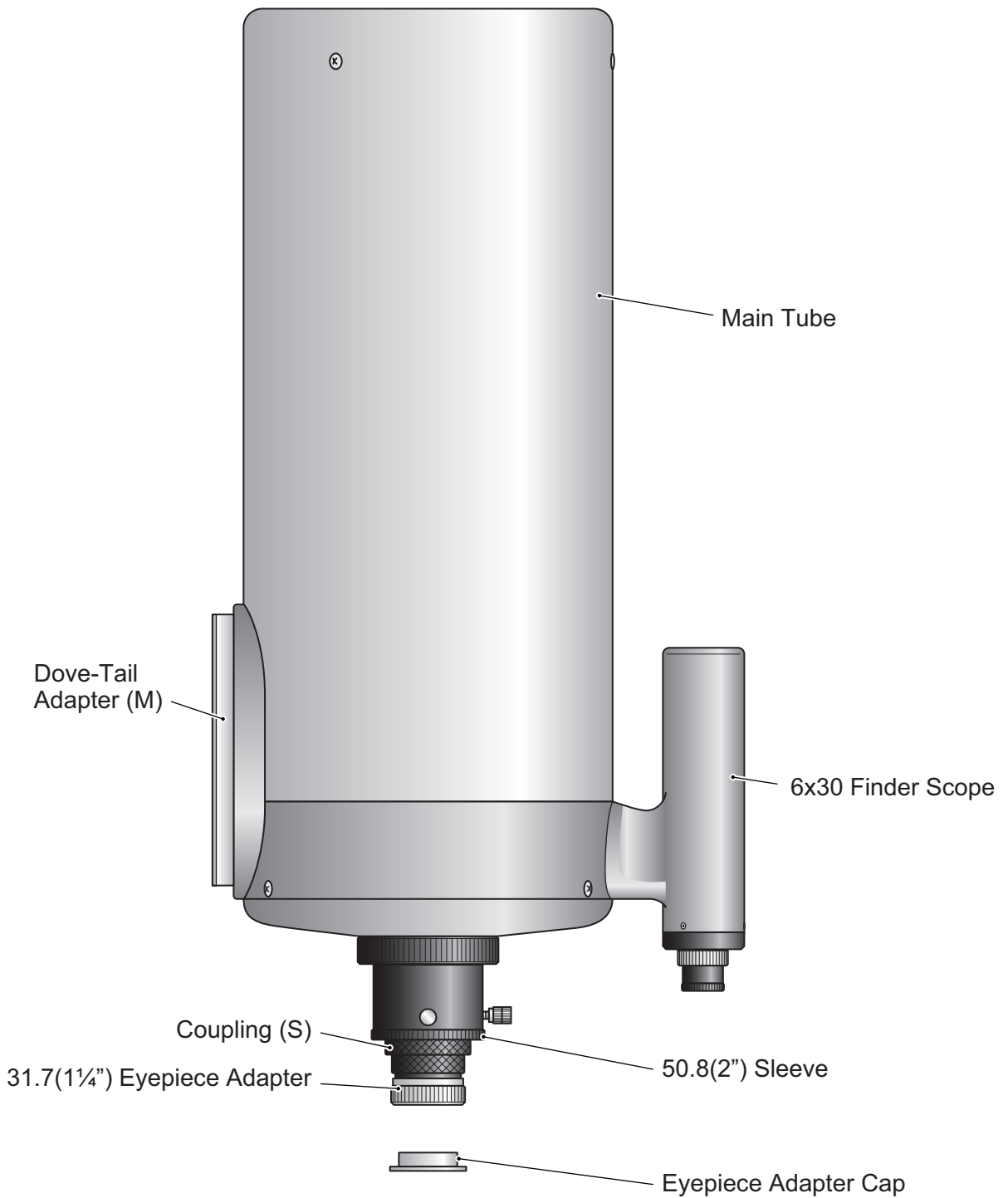

# Features

The Mewlon-180C is a Dall-Kirkham optical system best used visually for lunar and planetary observation, as well as imaging, and can be used for observation of deep space objects. The classical Cassegrain optical system uses a parabolic concave primary mirror and a convex hyperbolic secondary. This design eliminates spherical aberration, but it is difficult to produce the hyperbolic secondary and collimation is difficult. The Dall Kirkham design uses a concave elliptical primary mirror and a convex spherical secondary, so that any spherical aberration is corrected by this design approach using both mirrors for correction.

There is only trace spherical aberration in the center of the field of view of the Dall Kirkham, but towards the edge, there is increasing coma. In order to minimize the coma, the magnifying ratio of the secondary should be made smaller. The Mewlon-180C is designed with a long focal ratio of  $f/12$  with an  $f/3$  primary, a 4x secondary, plus an additional 10 baffles in the primary mirror baffle to reduce internal reflections and off axis coma.

The Dall Kirkham optical design is best suited for lunar and planetary viewing as well as the observation of small deep space objects that require higher magnification. However, the Dall-Kirkham is capable of producing images as good as those produced by a Newtonian reflector. This design can produce images visually, and by using CCD camera, Takahashi has successfully developed a compact and easy to use telescope for planet images of the highest quality.

The spherical secondary mirror has allowed the mirror making, assembling, and adjusting of the Dall-Kirkham to become easier. This has enabled Takahashi to provide high performance on a continuous basis. Additionally, a paring system is used to insure the best match between the primary and the secondary as they are produced as closely possible at the same time and due to this pairing, there is no quality difference between the mating mirrors. The new HR multi-layer mirror coating increases reflectivity by 7% as compared to the original Mewlon-180.

The Mewlon-180C tube is an open tube telescope. Since there is no corrector plate over the front of the tube, the mirror can equalize with the ambient temperature which will stabilize quickly, and the air inside the tube will stabilize turbulence. The Mewlon-180C, with its long focal length, will produce sharp high contrast images of the Moon and planets. Ten baffles have been placed inside the primary baffle tube to produce images with great contrast and excellent sharpness.

When the tube assembly is attached to the mount, the Mewlon holder has one part, the dove-tail attached to the tube assembly and the detached saddle plate which is attached to the mount. The tube assembly can be conveniently attached and removed from the mount, using this dove-tail system.

# Setup Procedures

## ◆ Attaching the Tube Assembly onto the Mount

Attach the dove-tail adapter (F) firmly on the mount with two cap bolts as shown.

The finder scope is built-in the tube assembly and is designed as the carrying handle. When setting the tube assembly on the mount, carry it with two hands as illustrated below.

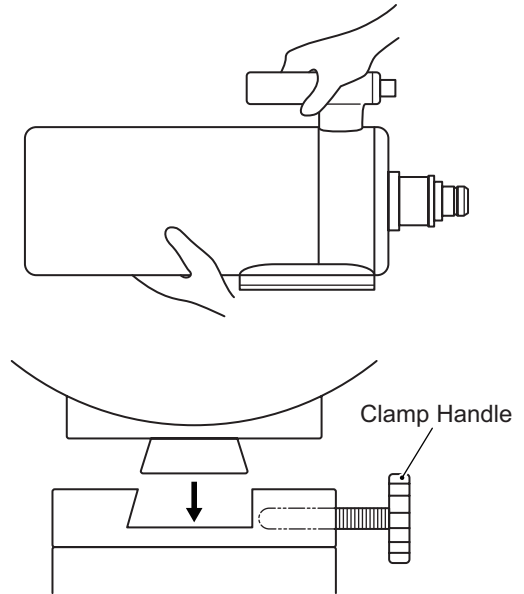
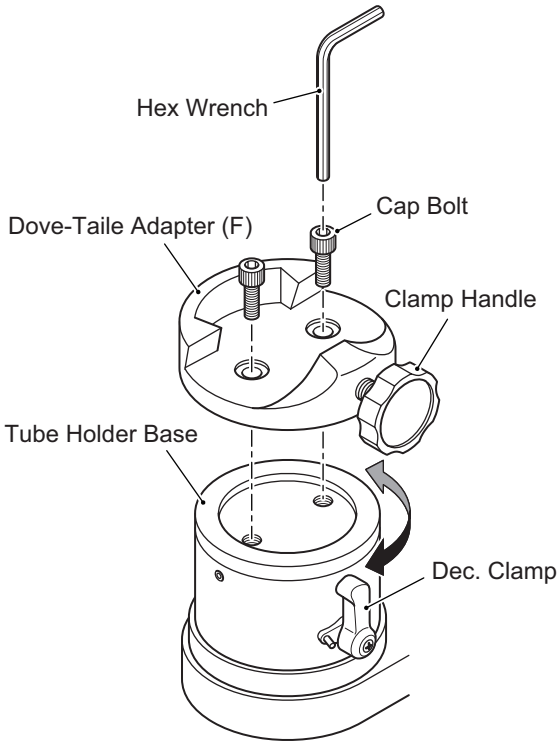

Loosen the Dec. clamp so the dove-tail adapter (F) is positioned as illustrated below and lock it firmly.

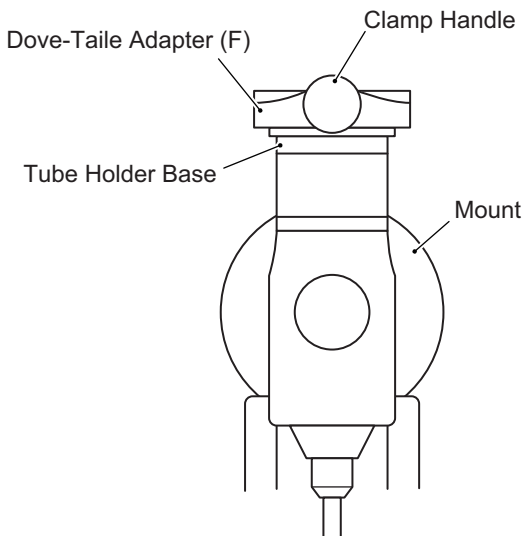



## ◆ Balancing

After the tube assembly has been attached on the mount, the next step is to balance it in the R.A. and Dec. axes. If unbalanced, the clamps will not work effectively and the tube assembly will abruptly and dangerously turn. When the motor of the mount is rotating, unbalancing will cause gearing trouble that will make the life of the mount shorter. When balancing, do it with all accessories necessary for observation attached to the tube assembly.

### ▼ Balancing around the Dec. axis

1. Loosen the Dec. clamp and lock it at the position that the Dec. axis becomes horizontal.
2. Loosen the handle of the dove-tail adapter (F) and move the tube assembly forward and backward until it balances. In the normal visual observation, place the tube assembly at the top of the dove-tail adapter as illustrated.

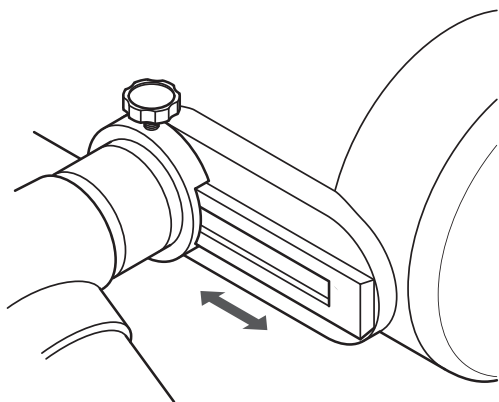

### ▼ Balancing around the R.A. axis

1. When balancing around the Dec. axis has been made, lock the Dec. clamp firmly.
2. Loosen the R.A. clamp and see balancing around the R.A. axis.
3. If unbalanced, move the counter-weight until it balances and lock the R.A. axis.
4. If unbalanced at the top of the counter-weight shaft, add an extra weight to balance.

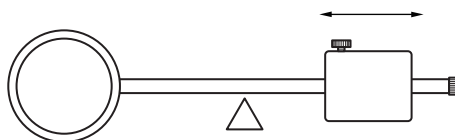

## ◆ Attaching an Eyepiece

Loosen the compression ring and insert an eyepiece into the eyepiece adapter. Then, tighten the compression ring to lock the eyepiece.

## ◆ Eyepieces

A wide variation of eyepieces are available from Takahashi.

### ▼ LE Series

Standard type, wide view field and high magnification. Available in:

- 31.7mm (1¼") barrel  
LE5mm, LE7.5mm, LE10mm, LE12.5mm, LE18mm, LE24mm, LE30mm
- 50.8mm (2") barrel  
LE50mm

### ▼ HI-LE Series

Long eye-relief, most suitable for planetary observation with high magnification. Available in:

- 31.7mm (1¼") barrel  
HI-LE2.8mm, HI-LE3.6mm

### ▼ Abbe Series

Simple 2-group 4-element eyepieces with high contrast, less expensive with high performance. Available in:

- 31.7mm (1¼") barrel  
Abbe 4mm, Abbe 6mm, Abbe 9mm, Abbe 12.5mm, Abbe 18mm, Abbe 25mm, Abbe 32mm

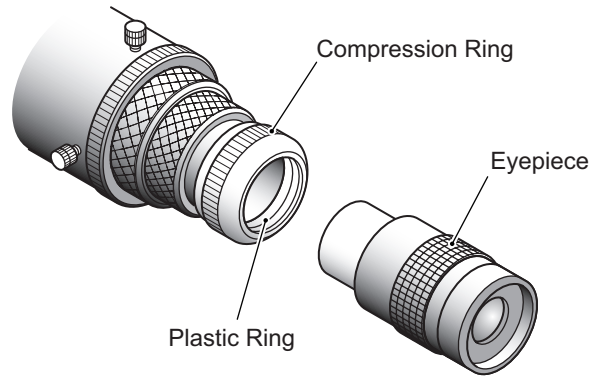

### ▼ Erfle

With 3-group 5-element optics, offering 60 degree apparent field of view, almost no flare and ghosting. Available in:

- 31.7mm (1¼") barrel  
Er-28mm

### ▼ TAK-UW Series

Ultra-wide angle with apparent field of 90 degree designed to get sharpest star images. Available in:

- 31.7mm (1¼") barrel  
TAK-3.3UW, TAK-5.7UW, TAK-7UW, TAK-10UW

## ◆ Attaching Accessories

Adapters and rings are attached to the visual back in order to use various accessories. Please check the system charts and attach the desired accessories correctly. Standard connection is as below.

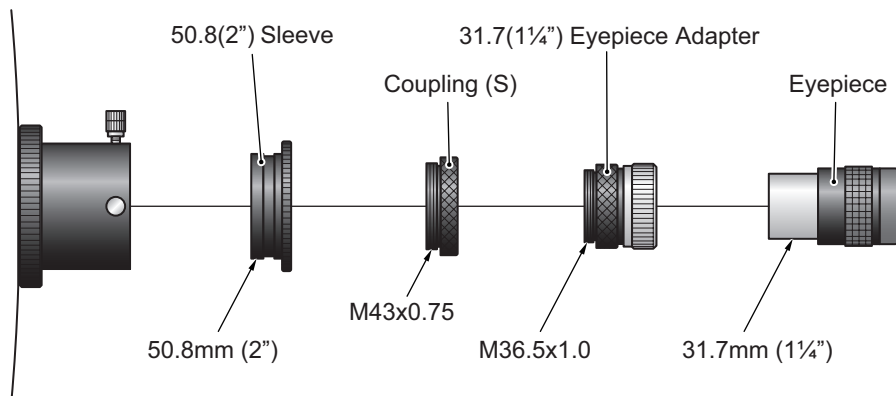

# Focusing

After an eyepiece has been attached on your telescope, precise focusing is needed to observe objects and landscapes clearly. If not correctly focused, your telescope cannot display its capabilities. Precise focusing is absolutely necessary especially in astro-imaging. Always use the best possible focus with the following procedures.

## ◆ Focusing System

Focusing this optical system is done by moving the primary mirror forward and backward using the focusing knob. The relation of the motion direction of the primary mirror and the focal point is as illustrated below.

When the focusing knob is turned counter-clockwise (OUT), the primary mirror is moved toward the secondary and then, the focal plane is moved outward. When the focusing knob is turned clockwise (IN), the primary mirror is moved toward mirror cell and then, the focal plane is moved inward.

### ⚠ Caution

The optical axis of the Mewlon-180C could become decollimated if the Mewlon is subjected to strong shocks during transport. In order to prevent the telescope from decollimating, the primary mirror is moved to the mirror cell. So, when focusing, turn the focusing knob in the OUT direction (counter-clockwise).

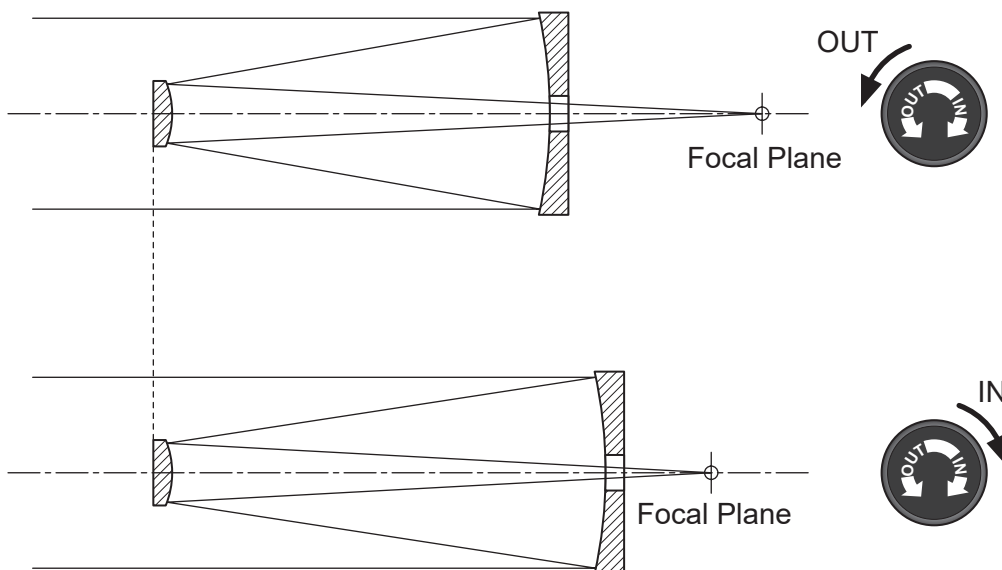

# Finder Adjustment

The field of view of a telescope can be highly magnified and narrow so that it is difficult to place an object in the field of view. In order to help you to find the object easily in the view field of your telescope, a 6x30 finder scope with wide field is provided with your telescope.

In order to see the same object in the view field of the main telescope and the finder scope, you must align the optical axes of the main telescope and of the finder scope. They must be parallel each other and then you can see the same object in the view field of both telescopes.

The finder scope attached to the tube assembly can be used also as the carrying handle. The finder can be adjusted by shifting the focusing unit using the adjusting screws. This system will hold the collimation of the finder to the main scope, but when necessary, realign the finder and main scope using the following procedure.

## ◆ Adjusting Focusing System

When you observe distant objects, you can adjust focus as follows.

1. Loosen the focus lock ring.
2. Find the focal point by turning the visual back clockwise and counter-clockwise, viewing the distant object.
3. When focused sharply, tighten the focus lock ring.

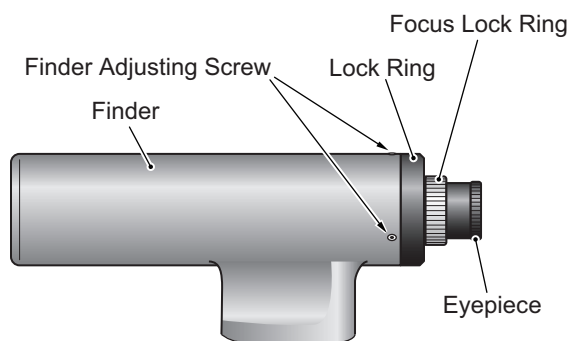

## ◆ Collimating the Optical Axis

The finder scope has been collimated at the factory before shipment. Therefore, usually the collimation is not needed when you purchase your telescope. However, if the collimation should be lost by some reason, you can adjust the collimation with the following procedures.

1. Set your telescope for visual use and attach a low power eyepiece. Then, center a distinct object as far away as possible in the field of view.
2. Change the eyepiece to one of higher power ones and center the object again. Then, lock the telescope's (illustration at the right) field of view of the finder scope and to the field of view of the main telescope.

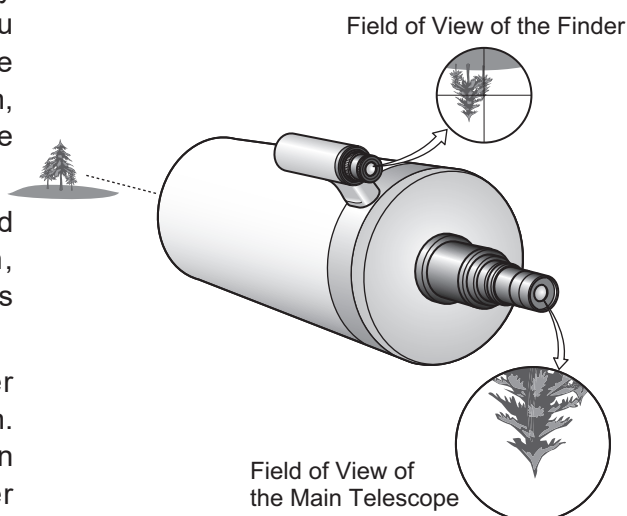

3. If the object is not centered in the field of view of both telescopes, adjust the finder using the following method so that the object is placed at the center of the crosshair.

4. Loosen the lock ring as illustrated.

5. Loosen all three adjusting screws enough so that the eyepiece can move freely.

6. Hold the visual back with one hand and adjust it so that the object at the center of the telescope is on the crosshair in the center of the finder, looking through the finder. Then, lightly tighten the lock ring with the other hand.

7. By turning all three adjusting screws with the Hex wrench, center the object precisely at the crosshair. If the object shifts as illustrated; loosen screw A and tighten B & C screws to move the object on the crosshair. When the object is positioned on the crosshair, tighten the adjusting screws firmly.

8. Finally, tighten the lock ring firmly and lock the visual back.

\*Please understand the relationship between the movements of the three adjusting screws and the movement of the object in the field of view, actually looking into the finder.

\*Please do the above procedures in the daytime to be ready for observation at night.

\*When the finder alignment is made by using a star, it will move during the alignment procedure due to the movement of the sky. Therefore, do alignment rapidly or use an equatorial mount with the motor drive running to keep the stars from moving in the field of view.

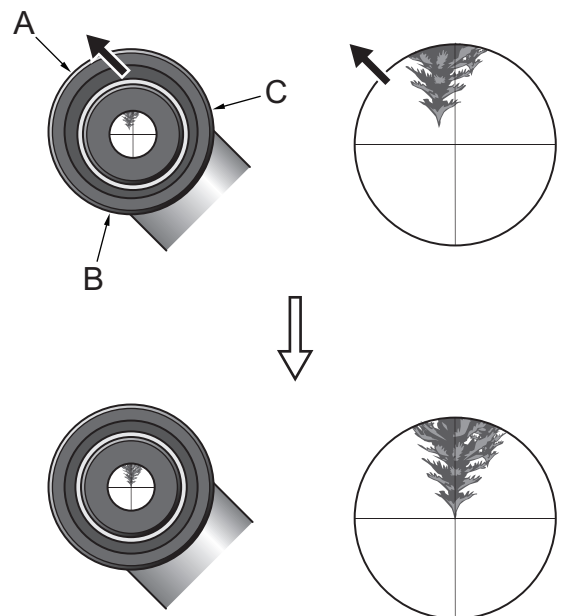
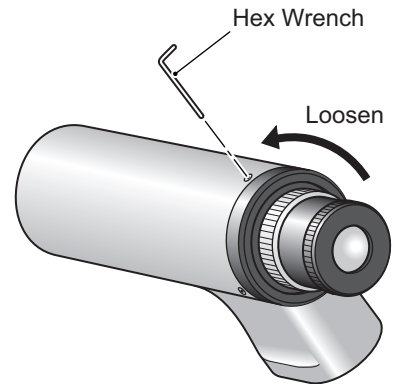

# Observation

## ◆ Preparation before Observing

A reflecting telescope like Mewlon-180C takes time to equalize the optical system with the ambient outside air temperature, especially when the outside temperature is low. Bring the tube assembly outside about one hour before observation and allow it to equalize with the outside ambient air temperature.

## ◆ Visual Observation

### ▼ Magnification

Magnification can be computed by using the following formula.

Focal Length of Telescope divided by  
the Focal Length of the Eyepiece

For example with LE18mm eyepiece  
 $2160\text{mm} / 18\text{mm} = 120$

Therefore, the shorter the focal length of an eyepiece is used, the higher the magnification. On the other hand, the longer the focal length of an eyepiece is used, the lower the magnification. It is a general rule that the upper limit of the magnification is 20x to the aperture in "cm" of a telescope and the lower limit is 1.4x to it. Therefore, the highest effective magnification of your Mewlon-180C will be 360x and the lowest 26x. Most of Takahashi eyepieces can cover this magnification range.

### ▼ Diagonal Mirror & Diagonal Prism

A diagonal mirror or a diagonal prism make it easy to observe comfortably. These are 90 degree diagonals, which are available from Takahashi. Further details of these parts, please refer to the next page.

## ◆ Astro Imaging

### ▼ Magnified Imaging

When imaging the craters of the Moon and planets, magnified imaging can be done with the parts optionally available. When imaging the Moon's surface, you can enjoy a wide variation of imaging because the Moon has ample illumination. In the case of planetary imaging, magnify it as large as possible according to seeing and illumination. When the seeing is bad, good imaging of the moon as well as planets will be impossible. Therefore, visually check the seeing before imaging and do it in when the conditions as good as possible. For magnified imaging, the TCA-4 is available from Takahashi together with various T-mounts to attach your DSLR camera to your telescope.

### ▼ Prime Focus Imaging

This is the method used to image an object that is focused by placing the imaging element at the prime focal point. In this method, a telescope is used as a telephoto lens for your camera. When Mewlon-180C is used as a telephoto lens with a camera, its focal length is so long that it will make star images degraded with even a slight error in guiding. Use a sturdy, quality equatorial mount like the Takahashi EM-200 T-2Z.

Cameras that can do prime focus imaging are the DSLR and CCD cameras available in the astro market. Various adapters to attach a camera to Mewlon-180C are available from Takahashi. Please refer to the system charts for further information.

# Accessories

Here are major accessories conveniently usable with the Mewlon-180C.

## ◆ Diagonal Mirror 50.8mm (2") & Diagonal Prism 31.7mm (1¼")

When either of these diagonals are used with an eyepiece, the light path is longer to set the secondary closer to the primary. In order to obtain sharp focus, use these diagonals as indicated in the system chart. Refer to the illustration of the light path length.

When the accessories other than eyepieces are used, the Diagonal Mirror is recommended to use because the light path length is same to that of the 50.8 (2") Extension Tube (L) and thus it is almost not necessary to refocus.

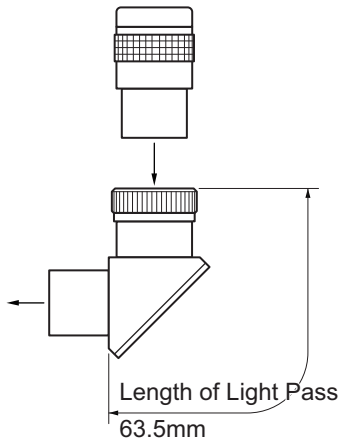

Diagonal Prism 31.7(1¼")

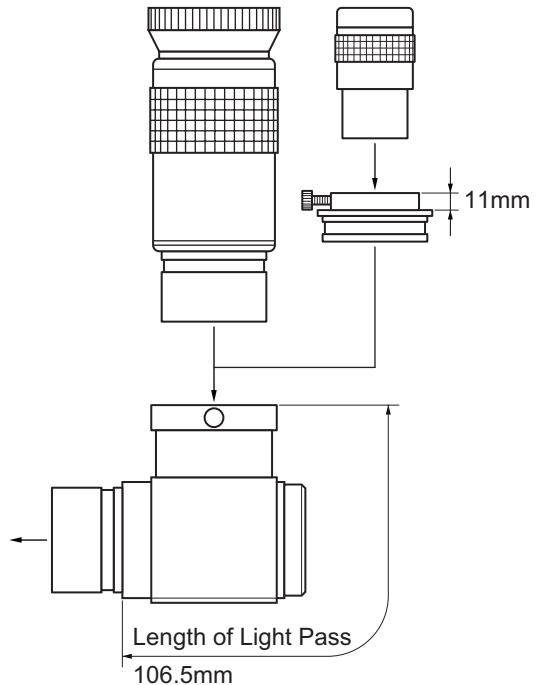

Diagonal Mirror 50.8 (2")

## ◆ 4-Turret Eyepiece Holder 31.7D

The 4-Turret Eyepiece Holder 31.7D is a convenient accessory that allows the observer to use 4 eyepieces with different magnifications and it is easily changed by turning the turret. This turret accepts 4 different eyepieces and allows eyepieces to be changed quickly by turning it. In addition, this device has a built-in 90 degree prism that allows to observer view the entire sky conveniently.

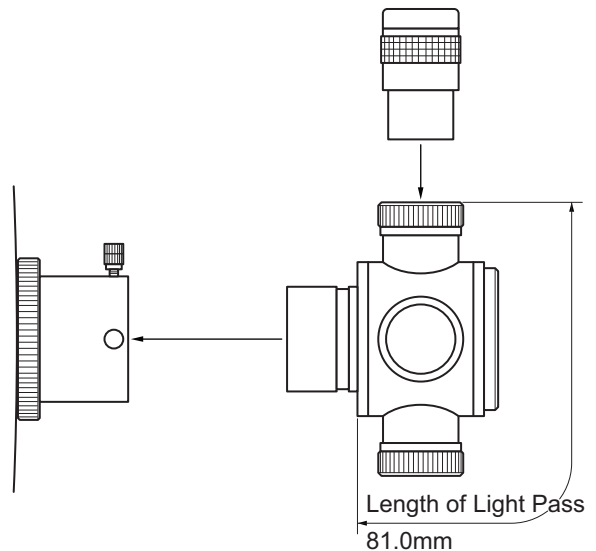

4-Turret Eyepiece Holder 31.7D

## ◆ TCA-4

This is a highly functional variable eyepiece projection adapter that can change quickly from visual observation to high magnification imaging. The magnifying eyepiece can be changed quickly. In addition, the magnification ratio can be changed at will by sliding the magnifying tube. Please refer to the illustration for connection details.

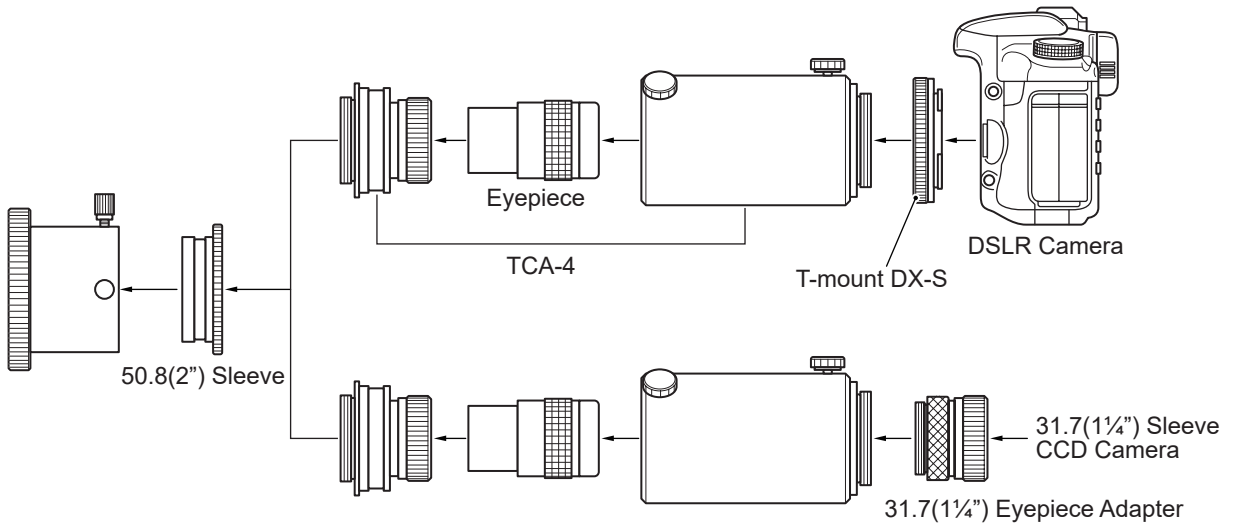

## ◆ Prime Focus Ring

In order to attach a DSLR camera, the Prime Focus Ring is necessary. Basically, the Prime Focus Ring (M43 → M42) and the T-Mount DX-S are used.

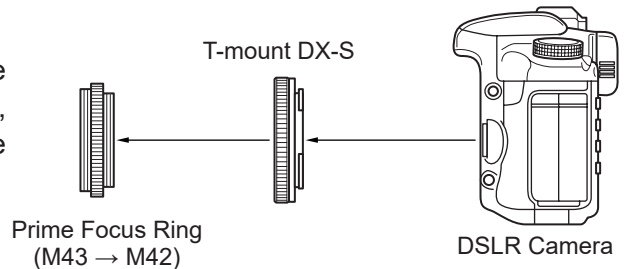

## ◆ Mount DX & DX-S

In order to attach a DSLR camera, the T-Mount DX-WR is used for the prime focus imaging with the Prime Focus Ring 50.8( $\phi$  50.8 → M54), and by the Flattener/Reducer and the T-Mount DX-S for magnifying imaging by the TCA-4, and the prime focus imaging with the Prime Focus Ring (M43 → M42). The T-Mounts are available for EOS and Nikon.

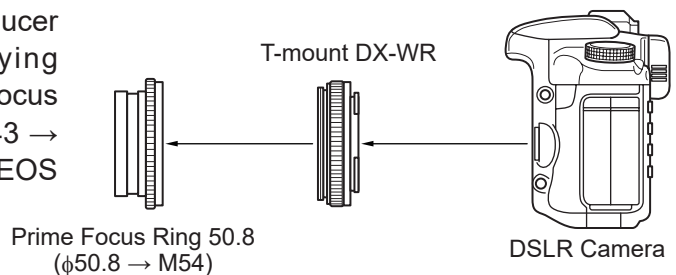



### ◆ Mewlon Flattener/Reducer

Due to relatively large coma, the Mewlon-180C is not suited for deep sky imaging at prime focus. However, you can enjoy deep sky imaging using the Mewlon f/9.8 Flattener/Reducer, which decreases the focal ratio to f/9.8 and reduces coma.

Focal Length : 1760mm

Focal Ratio : f/9.8

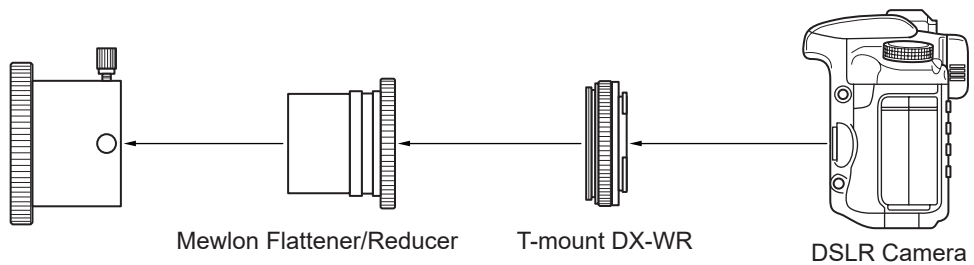

# Collimation

Collimating the optical axis of the Mewlon-180C is made possible by adjusting the tilt the secondary mirror. Therefore, you will have no such troublesome works as in the Newtonian telescope. The secondary mirror is an expanding optical system so that it is so sensitive to the collimation that a slight movement of the adjusting screw can make the optical axis out of order, resulting in the images degraded greatly.

The Mewlon-180C was checked at each stage of production with a collimator using an artificial star at the factory. It is collimated a final time before shipment. The optical axis of the Mewlon-180C is designed to hold collimation and is designed to hold alignment once collimated, but it might be out of alignment after transporting the telescope. Therefore, in order to use your telescope to the limit of its potential, you have to always keep its optical axis collimated. Before you start to do your astronomical observation, never fail to check if the optical axis is collimated. If it should be found to be misaligned, collimate the telescope using the following method. The scope should be collimated after about an hour to allow the optics to equalize with the outside temperature.

1. Remove the spider cover by turning it as arrowed, then the adjusting screws are exposed. Be careful not to drop the cap into the tube when removing the threaded cover.
2. Select a star brighter (mag 2 - 3) and higher in the sky and center it at the field of view.

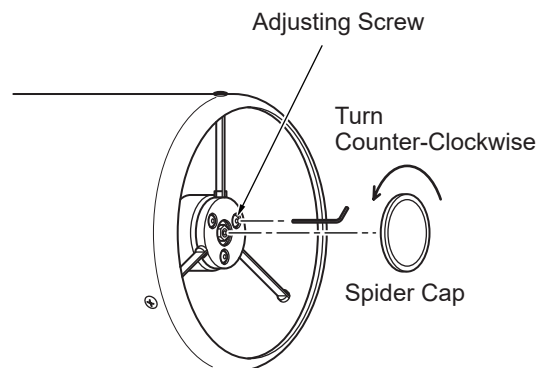

Focus it by turning the focusing knob and then defocus in and out from the focal point. Then, the inner and outer images are seen with the diffraction rings as shown. If the optical axis is correctly adjusted, the center dot, the inner ring, the intermediate ring, and the outer ring, all form a concentric circle in the in and out images. In case the optical axis is decollimated, the center of the circle is seen off. Then, collimation is required. (When the focusing knob is turned to "OUT" position from the focal point, you can see the inner image. Toward "IN" position, you can see the outer image.)

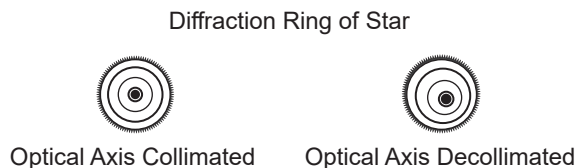

Decollimation can be easily checked with the image just in front of or behind the focal point. Off images will appear in the same direction so either image will do. Remember in which direction the off images appeared.

3. In order collimate the optical axis, adjust three correcting screws with the 2.5mm Hex wrench provided. If the axis is out of alignment as shown in the illustration at the right, tighten the screw at the right side, as seen from the tube opening. If the screw is not positioned in the right place, tighten the two other screws positioned near the place. Due to the mechanical structure for correction, tighten the correcting screw after the screw at the opposite side has been loosened. Repeat this procedure until the optical axis is collimated. Finally, defocus and see if the center dot, the intermediate ring, and the outer ring are seen as a concentric circle. Then the optical axis has been perfectly collimated.

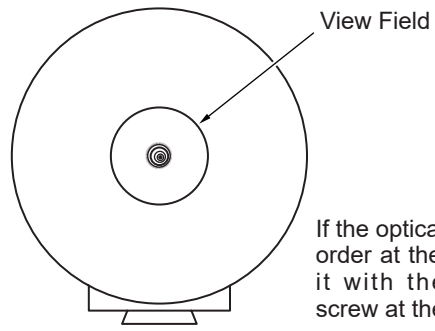

from the eyepiece.

If the optical axis is out of order at the right, correct it with the correcting screw at the right

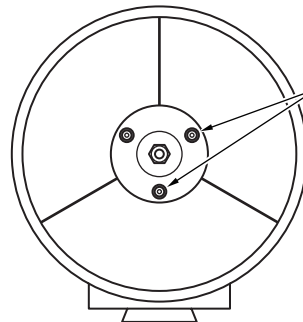

from the tube opening.

Tighten these two screws (refer to the illustration below)

- \* If all three screws are loosened too much, the secondary mirror holder might detach. Therefore, loosen these screws little by little with great care to make certain the alignment is done and make sure all the screws being correctly tightened, thus keeping the secondary mirror attached firmly in place.
- \* Sometimes a collimation star image can move out of field of view when the screws are moved. When a star image goes out of the center during the alignment procedure, continue the alignment, by replacing the star image with another at the center.

- \* The center of the diffraction ring might hardly be seen by the center obstruction of the secondary mirror.
- \* The alignment screws are not always positioned in the desired direction off-center of the optical axis. Refer to the diagrams below, where the example of how to adjust the alignment screws is shown.

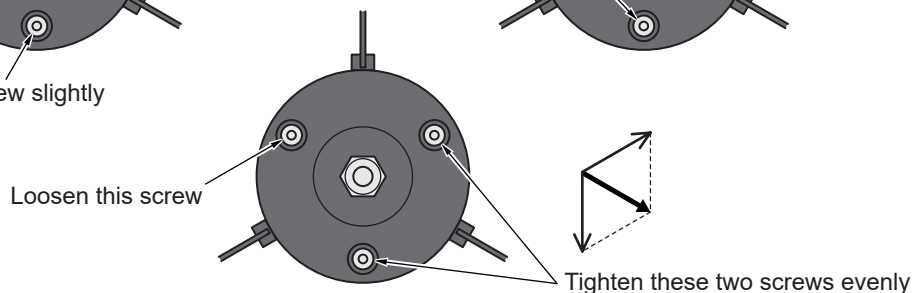
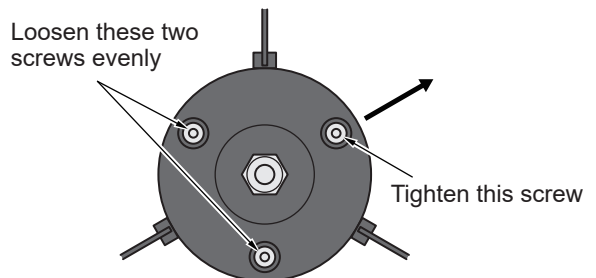
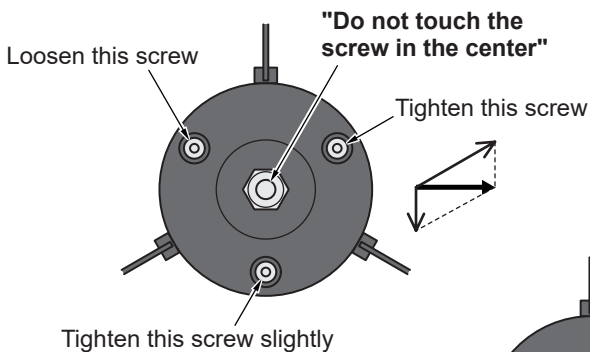

# Care & Maintenance

The primary mirror of the Mewlon-180C is exposed directly to the open air. If the surface of the mirror is left covered with dust and dew, it will become dim and reduce the contrast of images. Using the following procedures, clean up dust from the surface of the mirror using a hand blower at the regular intervals. When you set the tube back on to the mirror, set it precisely in place with the cell. Then, the optical axis will be hardly out of order.

1. Place the tube assembly on its front on a level surface.
2. Holding the visual back; stand the tube assembly on its front, take out the cell cap, and remove the three screws holding the primary mirror cell.
3. Pull up the primary mirror cell slowly, with great care not to touch the mirror to the inside wall of the tube. Especially watch these screw heads on the lower ring of the tube. Make sure the long baffle tube comes out completely from the tube. When the cell is tightly set, lift it out very slowly with great care.

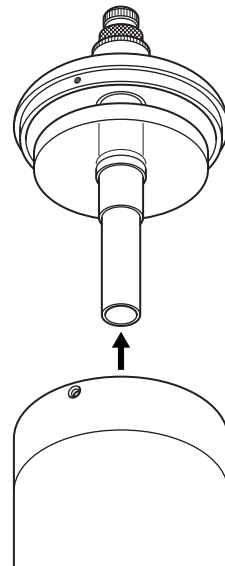
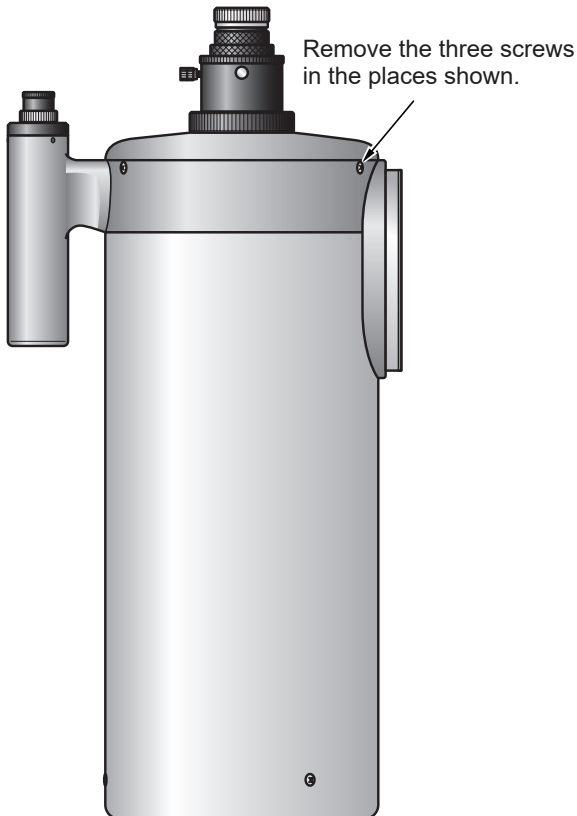

4. Place the primary mirror with the cell and the baffle on a desk as illustrated and blow off dust by a blower.

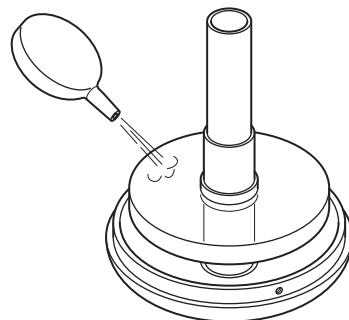

# System Charts

## ◆ Visual/Imaging System Chart

### ▼ Standard Accessories

- 13. TKP00113 50.8/2" Sleeve
- 14. TKP00103 Coupling (S)
- 46. TKP00101 31.7(1¼") Eyepiece Adapter

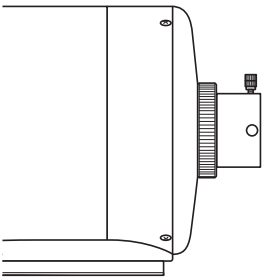

### ▼ Optional Accessories

- 18. TKA70581 Mewlon Flatener/Reducer
- 27. TKA00404 4-Turret Eyepiece Holder 31.7D
- 30. TKA00206 Prime Focus Ring (M43 → M42)
- 32. TKA01250 T-Mount DX-S (EOS)
- TKA01254 T-Mount DX-S (Nikon)
- 33. TKA01251 T-Mount DX-WR (EOS)
- TKA01255 T-Mount DX-WR (Nikon)
- 34. DSLR Camera
- 35. TKA00207 Prime Focus Ring (50.8/2")
- (φ 50.8 → M54)
- 36. TKA00210 TCA-4
- 47. 31.7(1¼") Eyepiece
- 48. 50.8(2") Eyepiece
- 49. TKA00547 Diagonal Prism (31.7/1¼") MC
- 74. TKA00543 Diagonal Mirror (50.8/2")
- 75. TKA00111 Adapter (DM)(31.7/1¼") AD

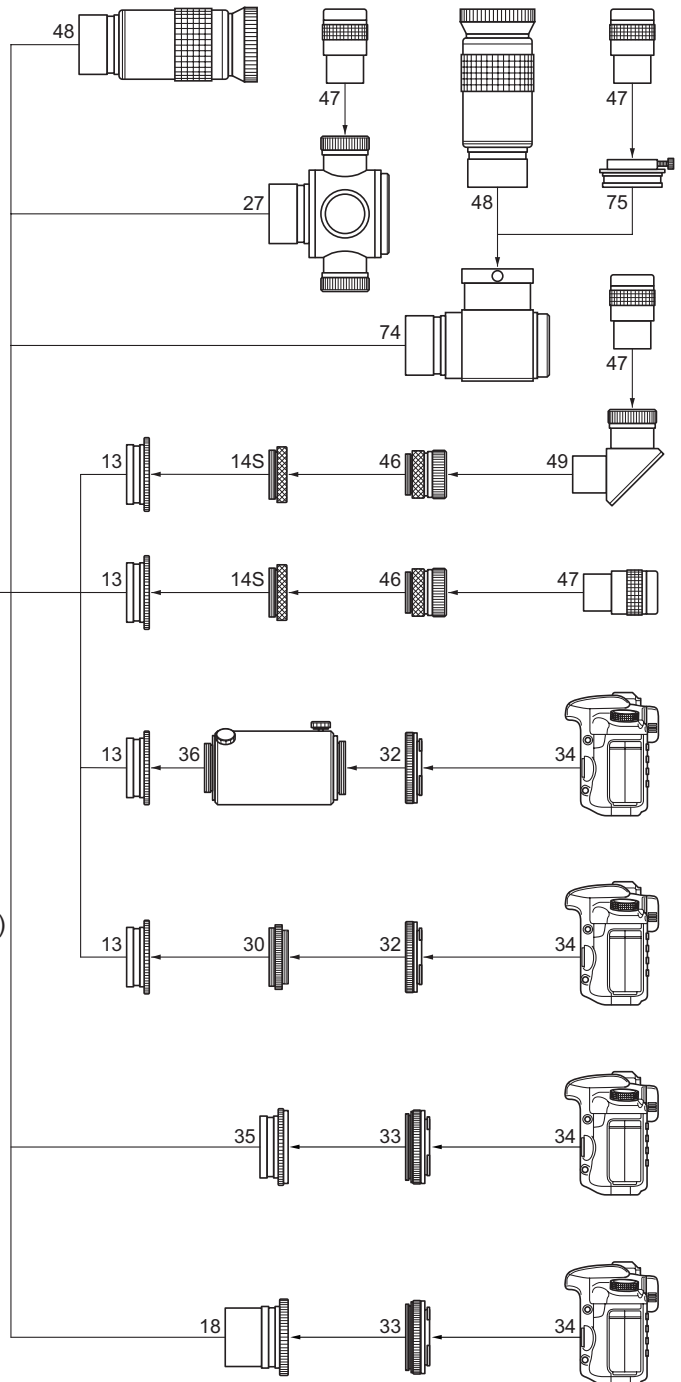

**(Note)** Some DSLR camera can not be attached to the system.

31.7/50.8 stand for 31.7mm/50.8mm.





**TAKAHASHI SEISAKUSHO Ltd.**

41-7, Oharacho, Itabashiku, Tokyo 174-0061, JAPAN

PHONE:+81-3-3966-9491 FAX:+81-3-3966-9524